

Program Schedule

COMBIBOX clutch-brake-combination type 10 / 09 / 06

with an energised to engage single sided clutch / brake	COMBIBOX	10
with an energised to engage single sided clutch without brake	COMBIBOX	09
with an energised to engage single sides clutch / and energised to disengage single sided permanent magnet brake	COMBIBOX	06

Technical data: Moment of inertia, friction work and calculations page 42

On request we adapt the **COMBIBOX** to your constructional and electrical requirements.

Design

Attachments

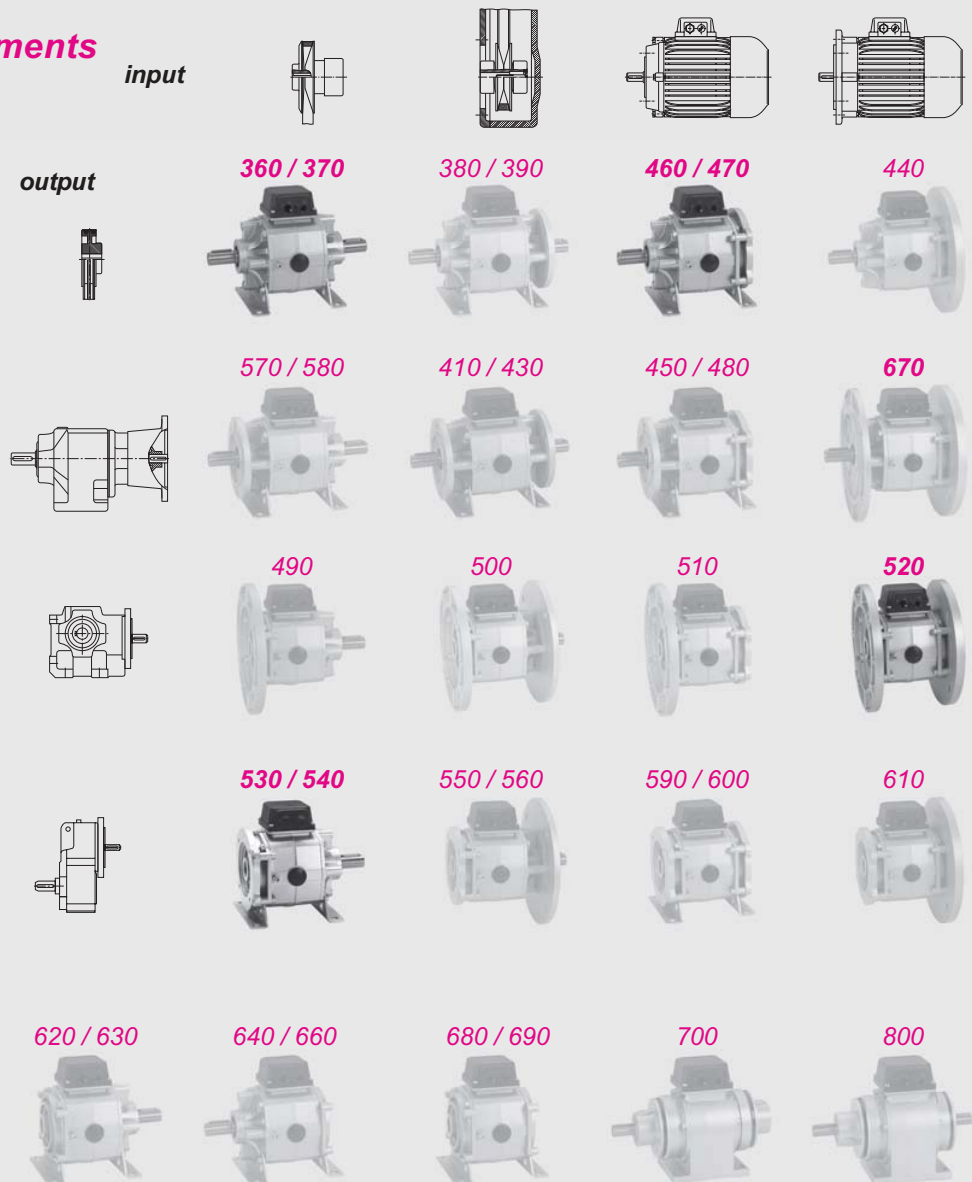

The **COMBIBOX** is a ready to install electromagnetic actuated clutch-brake module in a single housing.
 The modular system is designed for a multitude of variants; these covering most of the applications in the field.
 The patented adjustment procedure permits an air gap re-adjustment in it's installed condition. Thus giving a greater lifetime of the wear affected components.

The units designed for Start-Stop-operation considerably reduce the energy consumption due to a continuously running drive.



type 10

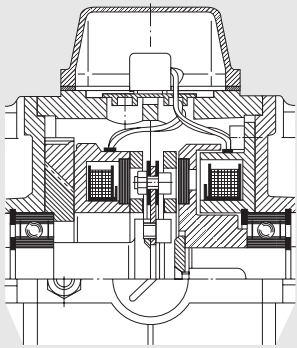

has an **energise to engage single sided brake**, this is the most commonly used, permitting high switching frequency and good positioning accuracy. The **COMBITRON** rapid switch can be used with this variant to achieve exceptionally high switching frequencies. The rated torque of both clutch and brake are identical.

type 09

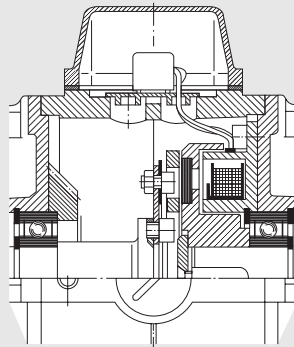

is the **COMBIBOX** version **without brake**, i.e. an electrical clutch in a housing for the use between e.g. motor and gear unit.

type 06

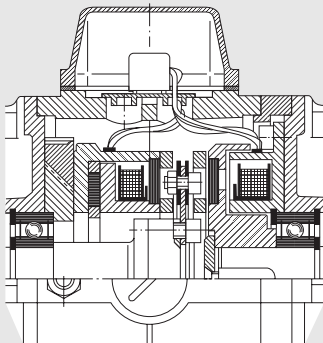

has an **energise to disengage permanent magnet single-side brake**. The characteristic of this variant is that the position of the output shaft is kept safe and backlash-free in currentless condition. The rated torque of the brake is slightly lower than that of the clutch.

COMBIBOX

COMBIBOX shaft in / shaft out

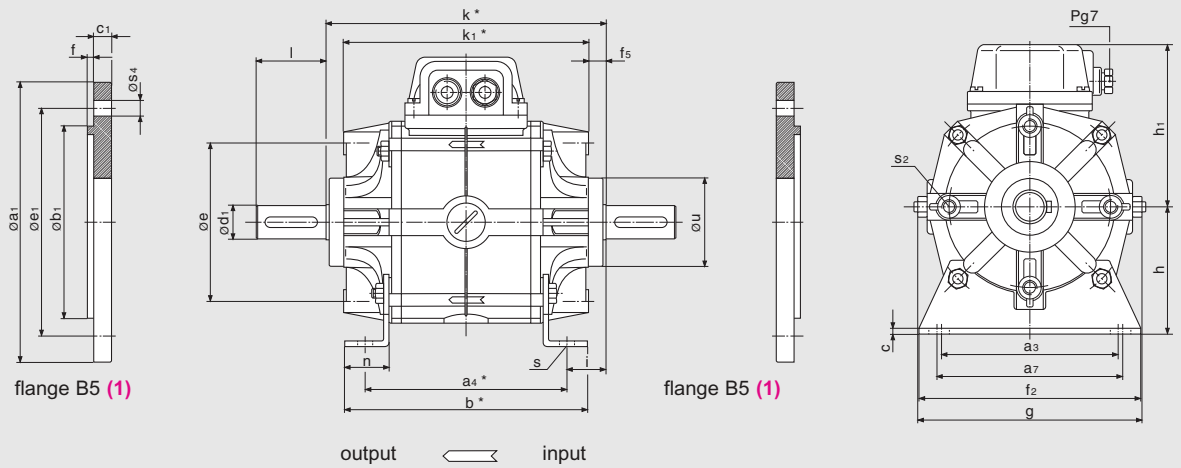

flange dimensions page 43

size	a ₃	a ₄	a ₇	b	c	e	f ₂	f ₅	g	h	h ₁	i	k	k1	n	s	s ₂	u	shaft		weight [kg]
																			d1	l	
06	80	100/109	85	115/124	3	72	100	10	103	63	87	18.4	137/146	117/126	18	7	M6	44	11 14	23 30	2.8/2.9
07	105	115/125	110	138/148	3	90	130	10	125	71	94	22.7	160/170	140/150	25	9	M8	50	14 19	30 40	3.9/4.1
08	130	135/147	140	160/172	4	112	160	12	158	90	108	30.6	196/208	172/184	28	9	M8	62	19 24	40 50	7.7/8.7
09	150	155/169	160	180/194	5	137	180	14	185	100	129	34.4	224/238	196/210	30	11	M10	74	24 28	50 60	12.5/15.0
10	185	185/202	195	215/232	6	175	223	18	236	132	154	50.6	286/303	250/267	38	13	M12	95	28	60	22.5/28.0
11	upon request																				

variations type 06 (marked in red)

rated torques 10 / 09 / 06

size		06	07	08	09	10	11
M _{2N} [Nm]	clutch	7	15	30	65	130	250 / -
	brake	7 / 6	15 / 12	30 / 24	65 / 50	130 / 120	250 / -
P ₂₀ [W]	clutch	15	20	28	35	50	68 / -
	brake	12 / 13	16 / 21	21 / 20	28 / 30	38 / 50	50 / -

all dimensions in mm keyways according to DIN 6885/1 centerings D according to DIN 332/2 Standard voltage 24 V DC VDE 0580, ISO-class „B“

part no.	feet	flange input B5 (1)	flange output B5 (1)
.....360			
.....370	X		
.....380		X	
.....390	X	X	
.....410		X	X
.....430	X	X	X
.....570			X
.....580	X		X

design type size

ordering specification:

- part number
- diameter of input-side flange
- diameter of input-side shaft
- diameter of output-side bore
- diameter of output-side flange
- operating voltage of COMBIBOX
- flange dimensions on page 43

Ordering example:

06. 10. 430
size type design

V DC, Ø a₁, Ø d₁ ?

COMBIBOX bore in / bore out

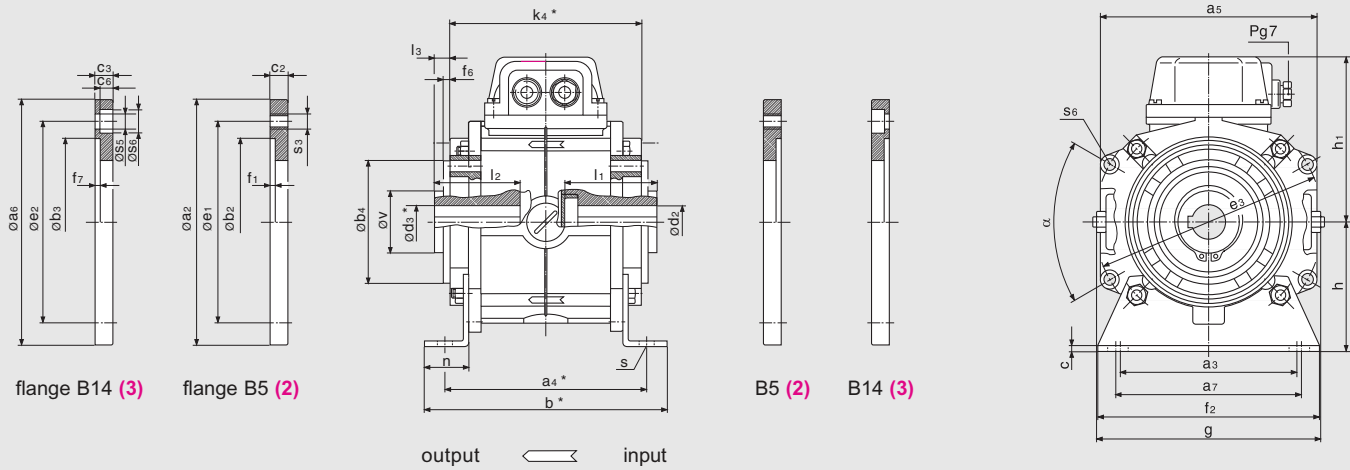

flange dimensions page 43

size	a ₃	a ₄	a ₅	a ₇	b	b h8	c	d ₂ G7 _{max}	d ₃ G7 _{max}	e ₃	f ₂	f ₆			Preferential-bore d ₂ and d ₃
06	80	100/109	104	85	115/124	60	3	15	15	108	100	4			11 or 14
07	105	115/125	123	110	138/148	70	3	24	24	128	130	4			14 or 19
08	130	135/147	155	140	160/172	80	4	28	28	165	160	4			19 or 24
09	150	155/169	178	160	180/194	95	5	35	35	190	180	5			24 or 28
10	185	185/202	229	195	215/232	110	6	42	42	242	223	5			28
11	upon request														

variations type 06 (marked in red)

size	g	h	h ₁	k ₄	l ₁	l ₂	l ₃	n	s	s ₆	v	a			weight [kg]
06	103	63	87	101 / 110	50	57	9	18	7	5.5	30	60			2.7 / 3.1
07	125	71	94	108 / 118	52	61	9	25	9	6.5	35	60			3.7 / 4.5
08	158	90	108	132 / 144	63.5	75	11	28	9	8.5	45	64			7.5 / 8.9
09	185	100	129	153 / 167	74	86	13	30	11	8.5	50	62			12.0 / 14.5
10	236	132	154	175 / 232	86	102	17	38	13	10.5	70	60			20 / 25.5
11	upon request														

all dimensions in mm keyways according to DIN 6885/1 centerings D according to DIN 332/2 Standard voltage 24 V DC VDE 0580, ISO-class „B“

part no.	feet	flange input		flange output	
		B5(2)	B14(3)	B5(2)	B14(3)
.....510			X	X	
.....520		X		X	
.....590			X		X
.....600	X		X		X
.....610		X			X
.....680					
.....690	X				
.....					

design
type
size

ordering specifications:

- part number
- diameter of input-side flange
- diameter of input-side shaft
- diameter of output-side shaft
- diameter of output-side flange
- operating voltage of COMBIBOX
- flange dimensions page 43

Ordering example:

06. 10. 600
size type design

V DC, Ø a₆, Ø d₂, Ø a₆, Ø d₃ ?

COMBIBOX

COMBIBOX bore in / shaft out

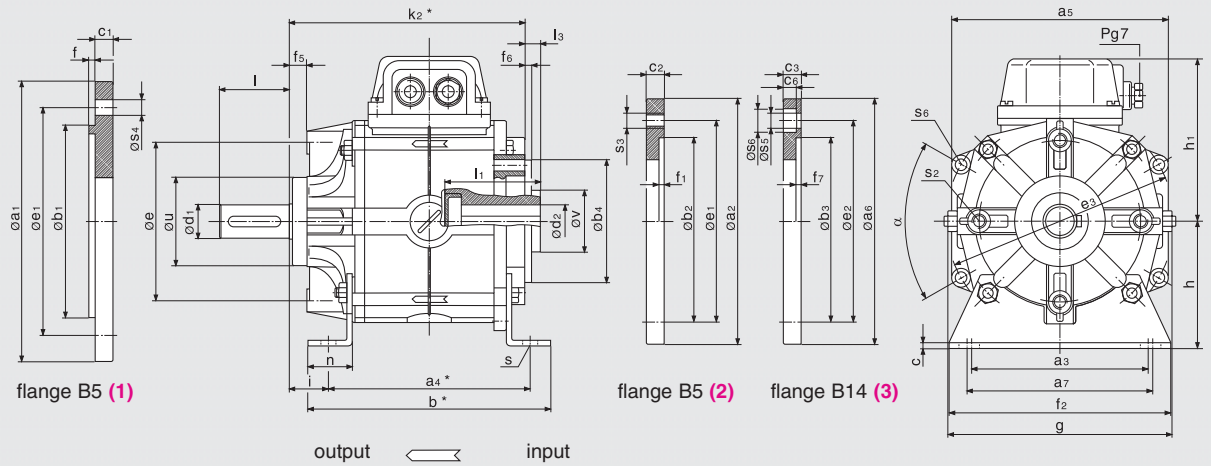

flange dimensions on page 43

size	a ₃	a ₄	a ₅	a ₇	b	b ₄ h8	c	d _{G7} ²⁺³ max	e	e ₃	f ₂	f ₅	f ₆	g
06	80	100/109	104	85	115/124	60	3	15	72	108	100	10	4	103
07	105	115/125	123	110	138/148	70	3	24	90	128	130	10	4	125
08	130	135/147	155	140	160/172	80	4	28	112	165	160	12	4	158
09	150	155/169	178	160	180/194	95	5	35	137	190	180	14	5	185
10	185	185/202	229	195	215/232	110	6	42	175	242	223	18	5	236
11	upon request													

all dimensions in mm keyways according to DIN 6885/1 centerings D according to DIN 332/2 Standard voltage 24 V DC VDE 0580, ISO-class „B“

rated torques 10 / 09 / 06

size	06	07	08	09	10	11
M _{2N} [Nm]	clutch	7	15	30	65	130
	brake	7 / 6	15 / 12	30 / 24	65 / 50	130 / 120
P ₂₀ [W]	clutch	15	20	28	35	50
	brake	12 / 13	16 / 21	21 / 20	28 / 30	38 / 50

all dimensions in mm keyways according to DIN 6885/1 centerings D according to DIN 332/2 Standard voltage 24 V DC VDE 0580, ISO-class „B“

part no.	feet	input flange		output flange
		B5(2)	B14(3)	B5(1)
... 440		X		
... 450			X	X
... 460			X	
... 470	X		X	
... 480	X		X	X
... 640				
... 660	X			
... 670		X		X

design type size

ordering specifications:

- part no.
- diameter of input-side flange
- diameter of input-side shaft
- diameter of output-side bore
- diameter of output-side flange
- operating voltage of COMBIBOX
- flange dimensions on page 43

ordering example:

06. 10. 450
 size type design

V DC, Ø a₆, Ø d₂, Ø a₁, Ø d₁ ?

COMBIBOX shaft in / bore out

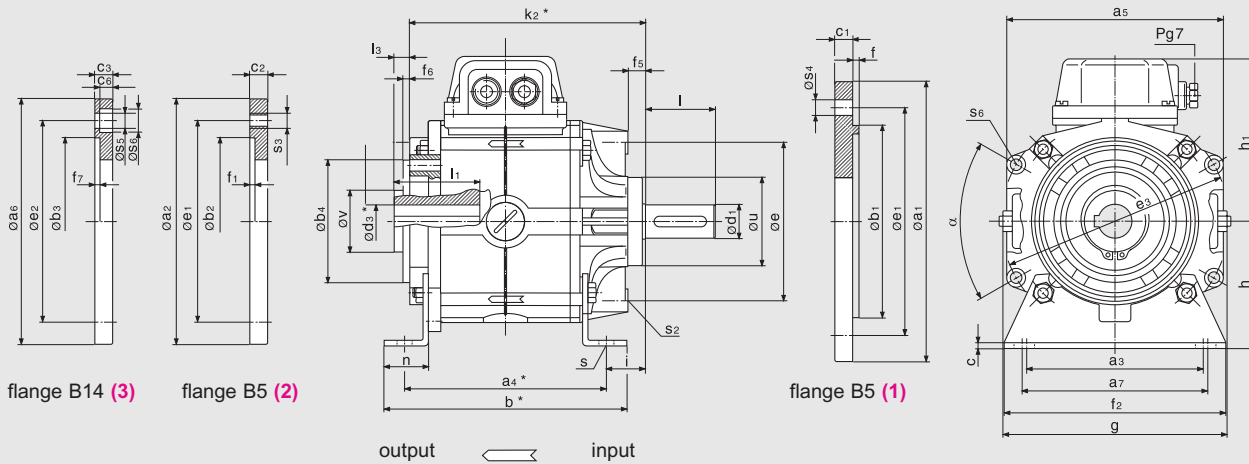

flange dimensions on page 43

h	h ₁	i	k ₂	l ₁	l ₃	n	s	s ₂	s ₆	u h8	v	a	Preferential bore d ₂ and d ₃	shaft d ₁ k6	l	weight [kg]
63	87	18.4	119/128	50	9	18	7	M6	5.5	44	30	60	11 or 14	11 14	23 30	2.8/3.1
71	94	22.7	134/144	52	9	25	9	M8	6.5	50	35	60	14 or 19	14 19	30 40	3.9/4.5
90	108	30.6	164/176	63,5	11	28	9	M8	8.5	62	45	64	19 or 24	19 24	40 50	7.7/8.9
100	129	34.4	189/203	74	13	30	11	M10	8.5	74	50	62	24 or 28	24 28	50 60	12.5/14.5
132	154	50.6	231/248	86	17	38	13	M12	10.5	95	70	60	28	28	60	22.5/26.0

variations type 06 (marked in red)

part no.	feet	input flange		output flange	
		B5(1)	B5(2)	B5(2)	B14(3)
...490			X	X	
...500		X		X	
...530					X
...540	X				X
...550		X			X
...560	X	X			X
...620					
...630	X				

design
type
size

ordering specifications:

- part no.
- diameter of input-side flange
- diameter of input-side shaft
- diameter of output-side bore
- diameter of output-side flange
- operating voltage of COMBIBOX
- flange dimensions on page 43

ordering example:

06. 10. 500
size type design

V DC, Ø a₁, Ø d₁, Ø a₂, Ø d₃ ?

COMBIBOX

Technical data

Combibox 06 / 09 / 10 size			type		06	07	08	09	10	11
M_{2N}	clutch	06/09/10	[Nm]	7	15	30	65	130	250	
		10		7	15	30	65	130	250	
		06		6	12	24	50	120		
P_{20}	clutch	06/09/10	[W]	15	20	28	35	50	68	
		10		12	16	21	28	38	50	
		06		13	21	20	30	50		
J	rotor	06/09/10	[10 ⁻⁴ kgm ²]	1.07	2.98	7.78	23.29	67.4	220	
		armature	06/09/10	0.84	2.62	8.59	23.08	91.07	330	
		armature	09	0.80	1.2	4.8	12.61	54.3	190	
W_{Rmax}		06/09/10	[10 ³ J]	1.9	3.1	4.8	0.75	1.25	2	
$W_{R0,1mm}$	clutch	06/09/10	[10 ⁶ J]	81	114	161	228	323		
		brake	06/10		59	80	114	164	236	
P_{Rmax}	clutch	06/09/10	[10 ⁶ J]	81	114	161	228	323	458	
		brake	06/10		59	80	114	164	236	339
X		06/09/10	[mm]	0.2	0.3	0.35	0.35	0.4	0.5	
X_n		06/09/10	[mm]	0.4	0.6	0.7	0.7	0.8	1.0	
n_{max}		06/09/10	[rpm]	3000	3000	3000	3000	3000	3000	

switching times		type 09/10 rated voltage [ms]				Typ 06 rated voltage [ms]			
clutch		t_{11}	t_1	t_2		t_{11}	t_1	t_2	
brake		t_2		t_{11}	t_1	t_1	t_1	t_2	t1
size	06	18	55	15	45	20	50	10	45
	07	25	95	20	60	25	85	14	50
	08	40	125	30	110	40	100	22	68
	09	50	200	40	160	50	200	30	150
	10	60	250	45	220	85	250	40	180
	11	100	300	80	260				

J	= moment of inertia ¹⁾	[kgm ²]	t_1	= Engaging time, time until 0.9 M_{2N} is reached	[ms]
M_{2N}	= rated torque ²⁾	[Nm]	t_{11}	= Engaging delay time, time until the armature is attracted	[ms]
P_R	= permissible friction per second	[J/s]	t_2	= Release time, time until the armature is attracted to the opposing side.	[ms]
P_{20}	= power input at 20 °C	[W]			
W_R	= friction	[J]			
$W_{R0,1}$	= friction work until an abrasion of 0,1 mm is reached	[J]			
X	= rated air gap	[mm]			
X_n	= clearance at which a readjustment is recommended	[mm]			

¹⁾ Sum of the moment of inertia reduced to the speed of the COMBIBOX plus the moment of inertia of the COMBIBOX parts to be accelerated or decelerated (J).

²⁾ The rated torques listed are safely attained after a run-in phase at 100 rpm. In new condition and for substantially higher speeds the torques are possibly lower.

Power supply

COMBIBOX requires d.c. voltage for actuation. The rated voltage of the magnets is 24 V DC standard. For operation with rectifiers the magnets are available in other voltages on specification.

The permanent-magnet brake installed in type 06 requires a smoothed supply voltage. To ensure a safe function in case of large temperature fluctuations, we recommend the supply of the coil with constant current.

Single-way or bridge rectifiers of the series COMBITRON 91 can be installed in the terminal box. Trafo rectifiers, electronic switches and rapid switches are also available.

Due to the exponential rise of the current in the coil the dynamic effect occurs delayed for all electromagnets. Therefore the full torque can be transmitted only after the time t_1 . Similar delays occur at switch-off.

COMBIBOX

size	IEC Ø ¹⁾	a1 (1)	a2 (2)	a6 (3)	b1 (1) h8	b2 (2) +0.3 +0.2	b3 (3) H8	c1 (1)	c2 (2)	c3 (3)	c6 (3)
06	90	90	105	105	60	60	60	10	10	10	5.5
	105	105	105	105	70	70	70	10	10	10	6.5
	120	120	120	120	80	80	80	10	10	10	6.5
	140	140	140	140	95	95	95	10	10	12	8.0
	160	160	160	160	110	110	110	10	12	12	8.0
07	105	110	120	120	70	70	70	10	10	10	6.5
	120	120	120	120	80	80	80	10	10	10	6.5
	140	140	140	140	95	95	95	10	10	10	6.0
	160	160	160		110	110		10	12		6.0
	200	200	200		130	130		10	14		8.0
08	120	130	-	160	80		80	12		12	6.5
	140	140	160	160	95	95	95	12	12	12	6.0
	160	160	160	160	110	110	110	12	12	12	6.0
	200	200	200	200	130	130	130	12	14	14	7.0
	250	250	250	-	180	180		12	14		
09	140	159	160	160	95	95	95	14	14	14	9.0
	160	160	160	160	110	110	110	14	14	14	9.0
	200	200	200	200	130	130	130	14	14	14	
	250	250	250	250	180	180	180	14	14	14	
10	160	-	200	200		110	110		18	18	9.0
	200	210	200	200	130	130	130	18	18	18	8.0
	250	250	250		180	180		18	18		
	300	300	300		230	230		18	18		
	350	350			250			20			
11	250	250	268		180	180		20	25		
	300	300	300		230	230		20	25		
	350	350	350		250	250		20	25		
size	IEC Ø ¹⁾	e1 (1 + 2)	e2 (3)	f (1)	f1 (2)	f7 (3)	s3 (2)	s4 (1)	s5 (3)	s6 (3)	weight [kg] (1/2/3)
06	90	75	75	2.5	3	3	M5	5.5	5.5	10	0.16
	105	85	85	2.5	3.5	3	M6	7.0	6.5	11	0.17
	120	100	100	3	3.5	3.5	M6	6.5	6.5	11	0.2
	140	115	115	3	3.5	3.5	M8	9	8.5	14	0.28
	160	130	130	3.5	4	4	M8	9	8.5	14	0.45
07	105	85	85	2.5	3.5	3	M6	M6	6.5	11	0.21
	120	100	100	3	3.5	3.5	M6	6.5	6.5	11	0.22
	140	115	115	3	3.5	3.5	M8	9	9	14	0.3
	160	130		3.5	4		M8	9		14	0.33
	200	165		3.5	4		M10	11		18	0.55
08	120	100	100	3		3.5		7	6.5	11	0.45
	140	115	115	3	3.5	3.5	M8	9	9	14	0.48
	160	130	130	3.5	4	4	M8	9	9	14	0.5
	200	165	215	3.5	4	4.5	M10	11	14	18	0.8
	250	215		4	4.5		M12	14			1.4
09	140	115	115	3		3.5		9	9	15	0.5
	160	130	130	3.5	4	4	M8	9	9	15	0.55
	200	165	165	3.5	4	4	M10	11	11		0.63
	250	215	215	4	4.5	4.5	M12	14	14		0.95
10	160		130		4.5	4.5	M8		9	15	0.9
	200	165	165	4	4.5	4	M10	11	11	18	1.1
	250	215		4	4.5		M12	14			1.2
	300	265		4	5		M12	14			1.25
	350	300		5				18			6.5
11	250	215		4	4.5		M12	14			
	300	265		4	4.5		M12	14			
	350	300		5	5.5		M16	18			

¹⁾ according to DIN IEC 34 standard flange

COMBIBOX