

Air Tube Disc Clutches and Brakes

Typical Applications

Wichita High Torque Clutch provides fast acceleration and long life on metalforming punch presses.

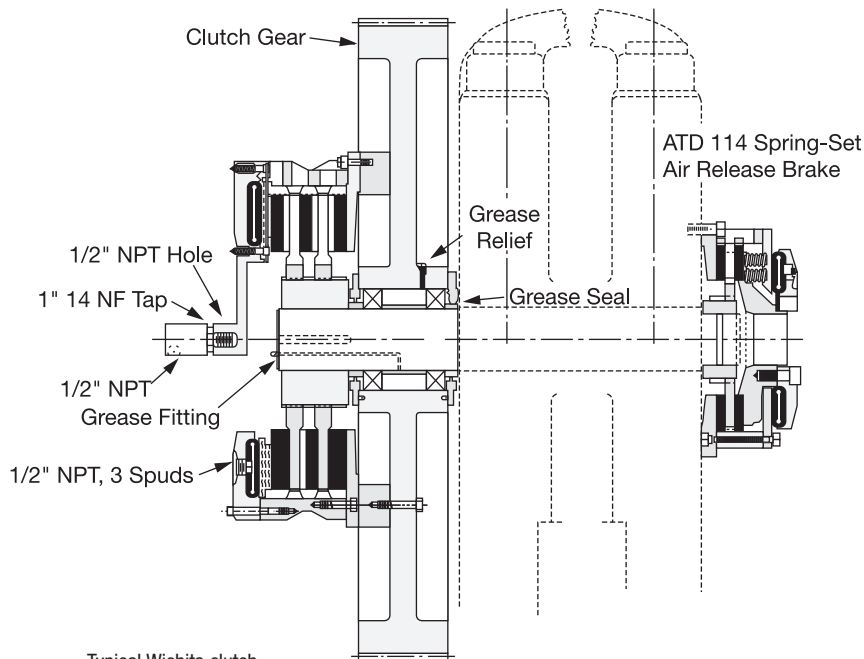
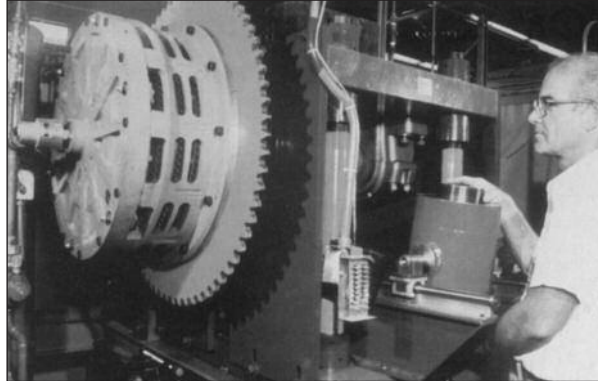

Typical Wichita clutch and brake mounting on a press

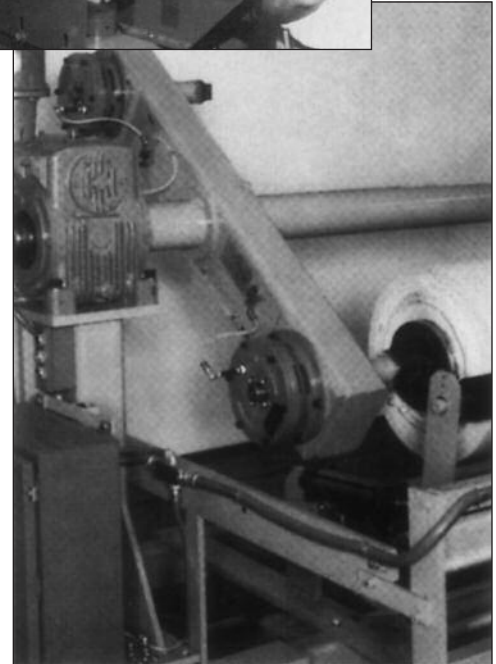

Wichita Low Inertia Brakes increase tension control for paper unwind stands.

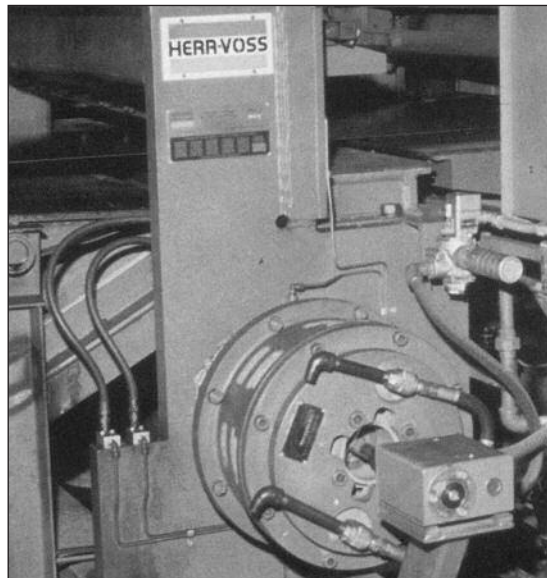

Wichita Spring-Set Air Release Brakes insure accuracy and high performance for a metal shear.



Air Tube Disc Clutches and Brakes

Application Factors

Clutch sizes are affected by the following variables:

- Machines that operate under smooth loads require smaller clutches. These machines are driven by either multi-cylinder high speed engines or electric motors with reduced starting current.
- Drives that require high starting current motors will require clutches with sufficient torque to prevent excessive slipping while starting.
- Starting torque may be high, which requires a fast clutch response time to transmit the required torque; or, extended clutch slip time is required to protect the prime mover.
- Starting torques may be very low compared to the normal torque, which may result in the clutch not being fully pressurized prior to the time of full torque requirement. This will cause the clutch to overheat from slippage. Clutch inflation time in this instance is very important.
- Clutches on most machines are designed to slip prior to damage from shockloads. As a result, the clutch may require periodic maintenance; therefore, the clutch should be located for easy access in the power train. Clutches should also be located for maximum cooling air. In instances where this is not possible, forced air cooling may be necessary for extended clutch life.
- Safe clutch operating speeds should be maintained in product design.

Maximum Clutch Contact Velocity	
FPM	Material
6,000 (Recommended)	cast iron
9,000 (upper limit for slip)	ductile iron
12,000	steel

Dynamic balancing recommended when peripheral speeds exceed 3500 FPM. The maximum speeds shown are safe operating speeds based on years of Wichita testing. Please do not exceed these limits.

Application Guidelines

This chart gives application factors ranging from light duty (the A group) to extra heavy duty (the D group).

After initial usage is determined, see

“Selection Requirements” to complete the selection process. The inflation and exhaust time should also be checked to insure proper response.

Field of Application	Group A	Group B	Group C	Group D
Pumps		Centrifugal compressors	Reciprocating compressors over 2 cylinders, centrifugal fans & blowers	Reciprocating compressors one or two cylinders
Agitators	Liquid	Semi-solid	Solids	
Brick manufacturing			Brick press, extruder, pug mill	
Canning & bottling machine		Bottle-can feeders, filling, mixers		
Engine driven equipment			Crane, hoist, engine	Crowd
Grinding mills			Ball-rod-sag-pebble	Crushers, shakers
Lumber processing		Yarder	Carriages, conveyers	Chipper, logger
Marine		Propulsion clutch CP wheel	Shaft brakes, propulsion reversing type, anchor winch	
Bulk material handling	Conveyors evenly loaded, line shaft evenly loaded	Feeders	Elevators	
Metal production & metalforming		Coilers, slitters, press brake, non-g geared press, geared press	Draw bench, rolling mill, shear, back geared press, deep draw press, transfer press, toggle press	Hammer mill, forming press, forging press, header press, knuckle press
Paper industry dryer sections & calenders Consult factory			Fourdrinier to 500 FPM, paper mill plane & smoothing press	Fourdrinier to 1800 RPM press selections, calenders & dryers
Petroleum production		Drilling & service rig master clutches, compound clutches, rotary, drum		Mud pumps, PTO clutches
Rubber manufacturing	Transfer machines evenly loaded		Banberry mixer, drum mixer, extruder, calender	Centrifuge

Air Tube Disc Clutches and Brakes

Low Inertia and Very Low Inertia Clutches and Brakes

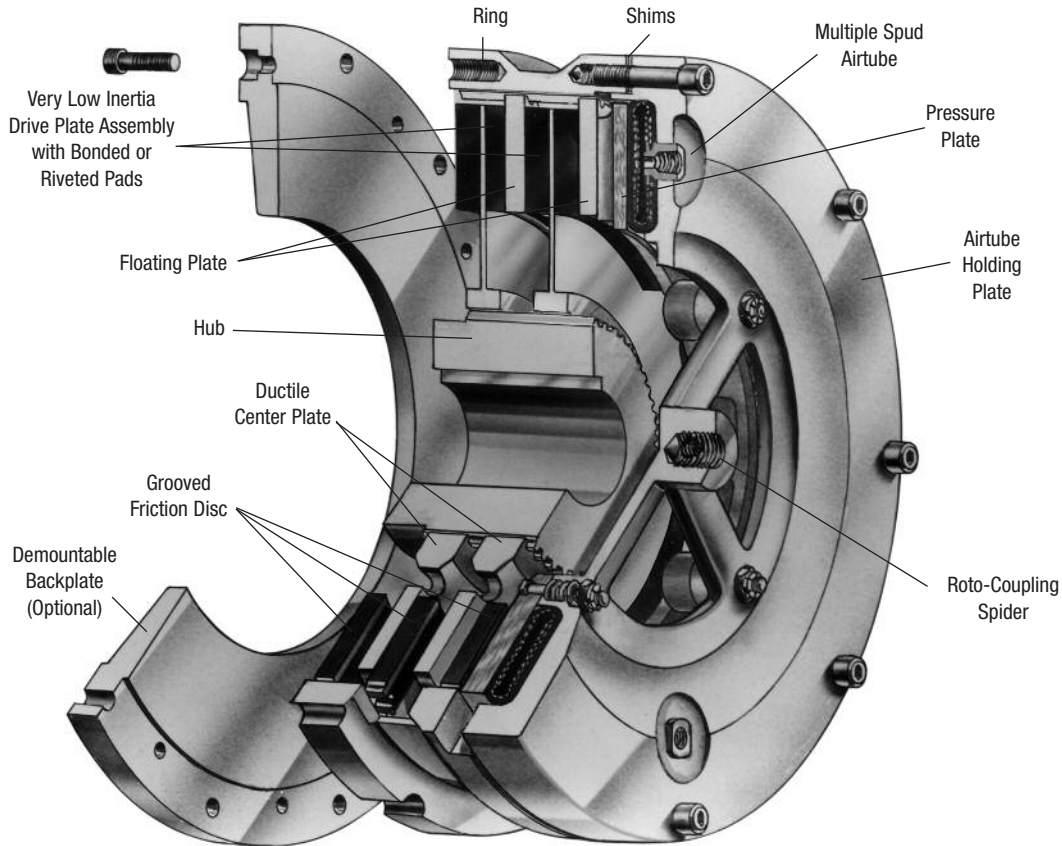

Operating Features

The Wichita Air-Tube Disc Clutch combines all the best features of the disc type clutch with all the advantages of direct air engagement. The simplest and most trouble-free method of applying air pressure is through direct axial pressure application by compressed air in a special composition full-circle tube.

Wichita Clutches engage smoothly without noise, shock or impact and release completely in a fraction of a second. Extremely fast action is possible because of the small volume of air required.

Clutches may be slipped moderately to control the acceleration rate.

When large inertia loads are powered from electric motors, smooth, controlled slip starts by Wichita Clutches can keep power demands below the allowed maximum.

Heat generated by controlled slipping or high cycle rate operation is dissipated by the centrifugal blower design of these units.

Wichita Low Inertia and Very Low Inertia Clutches and Brakes are designed to be completely free from effects of centrifugal force and self energization.

Torque developed is in direct proportion to air pressure applied.

These clutches and brakes interface well with automated controls through simple air and/or electric circuits.

Water cooled, copper disc clutches are available for use when power transmission needs require excessive or constant slipping which demands higher heat dissipation.

Wichita Clutches operate perfectly when teamed with Wichita Brakes in production situations requiring tension control, cyclic duty, or positioning.

Wichita Brakes have the same outstanding performance characteristics as Wichita Clutches.

Air Tube Disc Clutches and Brakes

Low Inertia and Very Low Inertia Clutches and Brakes

Selection Requirements

The selection of a Low Inertia Brake is based on:

1. Torque required to stop a load.
2. Friction area necessary to absorb rotational energy.
3. Contact velocity of rotating discs.
4. Maximum bore capacity of unit.

Selection example

To properly select a Low Inertia Brake for a controlled deceleration application, the following information is needed:

Speed 750 RPM
Shaft Dia. 5 in.
Inertia to Stop 2,473 lb.ft.²
Stop Time 5 sec.
Air Pressure Available 80 PSI

Calculations

$$\begin{aligned} \text{Avg. HP} &= \frac{WR^2 \times (\text{RPM})^2}{3.2 \times 10^6 \times \text{Stop Time}} \\ &= \frac{2,473 \times (750)^2}{3.2 \times 10^6 \times 5 \text{ sec.}} = 87 \text{ HP} \end{aligned}$$

$$\begin{aligned} \text{Swept Friction Area} &= \frac{\text{Avg. HP}}{\text{HP absorption rate for 5 seconds (see page 174)}} \\ &= \frac{87 \text{ HP}}{0.43} = 202 \text{ in.}^2 \end{aligned}$$

$$\begin{aligned} \text{Torque} &= \frac{WR^2 \times \text{RPM}}{25.5 \times \text{Stop Time}} \\ &= \frac{2,473 \times 750}{25.5 \times 5} \\ &= 14,547 \text{ lb.in.} \end{aligned}$$

Using the above calculations, consult the Low Inertia Specifications Chart on pages 26 and 27.

Summary

As calculated, the torque required to stop the load in 5 seconds is 14,547 lb.in. Wichita Low Inertia Brakes are rated at 100 PSI. This application has only 80 PSI available.

To determine the torque rating of a Low Inertia brake at 80 PSI apply the following formula:

$$\begin{aligned} \text{Application: Torque for a Low Inertia Brake} &= \frac{\text{Torque X Catalog Rated Pressure}}{\text{Available Air Pressure}} \\ &= 14,547 \times \frac{100}{80} = 18,183 \text{ lb.in.} \end{aligned}$$

Consult pages 26 and 36 for clutch and brake specifications. A Low Inertia model 114 Brake produces 27,625 lb.in. torque at 100 PSI. However, the bore capacity is 4.125 inches. This application requires a 5 inch bore. Therefore, a Low Inertia 118 is to be investigated.

Catalog Torque Rating = 64,500 lb.in. @ 100 PSI
Maximum Bore Capacity = 5.25 in.
Catalog Swept Friction Area = 264 in.²

Calculations show this application needs at least 202 in.² to absorb the heat.

All of these ratings are acceptable for the given application data.

Next, check contact velocity of rotating discs.

$$\begin{aligned} &= \frac{\text{Diameter of centerplate X RPM}}{3.82} \\ &= \frac{18'' \times 750}{3.82} \\ &= 3,534 \text{ FPM} \end{aligned}$$

Standard material is sufficient up to 6,000 FPM (see page 23). Balancing is recommended above 3,500 FPM.

Therefore, a Low Inertia ATD-118 brake is the optimum choice for this application.

A Spring-Set Air Release Brake is also available (see page 58).

Note:

This application example is for preliminary sizing only. Contact a Wichita Sales Engineer or the factory for final selection.



Air Tube Disc Clutches and Brakes

Low Inertia Clutches Specifications

Model Size ATD-	Assembly Number	Drawing Number	Slip Torque Capacity				Duty Factors HP/100 RPM				Max. Bore Rect. Key	
			lb.in.		Nm		A	B	C	D	in.	(mm)
			80 PSI	100 PSI	5.5 BAR	7 BAR						
LIC 106	6-006-100-211-0	-100-900-9	3,160	3,950	340	435	6.2	4.4	2.2	1.1	2.00	(50)
LIC 206	6-006-200-200-0	-200-900-9	6,320	7,900	680	870	12.5	8.8	4.4	2.2		
LIC 108	6-008-100-103-0	D-1718	5,600	7,000	620	790	11.1	8	4	2	2.25	(57)
LIC 208	6-008-200-101-0	-200-900-9	11,200	14,000	1,240	1,580	22.2	16	8	4		
LIC 308	6-008-300-103-0	D-2843	16,800	21,000	1,865	2,375	33.3	24	12	6	2.50	(64)
LIC 111	6-011-100-102-0	-100-900-9	12,720	15,900	1,400	1,785	25	18	9	5		
LIC 211	6-011-200-102-0	-200-900-9	25,440	31,800	2,800	3,570	50	36	18	10		
LIC 311	6-011-300-100-0	B-322	38,160	47,700	4,235	5,390	75	54	27	15	3.50	(89)
LIC 114	6-014-100-102-0	-100-900-9	22,100	27,625	2,435	3,100	44	31	16	8		
LIC 214	6-014-200-104-0	-200-900-9	44,200	55,250	4,870	6,200	88	62	32	16		
LIC 314	6-014-300-100-0	B-329	66,300	82,875	7,355	9,365	132	93	48	24	4.00	(102)
LIC 116	6-016-100-100-0	D-327	30,270	37,838	3,360	4,275	60	46	24	12		
LIC 216	6-016-200-100-0	-200-900-9	60,541	75,676	6,720	8,550	120	92	48	24		
LIC 316	6-016-300-100-0	D-1205	90,811	113,514	10,080	12,825	180	139	72	36	4.75	(121)
LIC 118	6-018-100-100-0	-100-100-0	51,600	64,500	5,705	7,260	102	75	35	21		
LIC 218	6-018-200-100-0	-200-900-9	103,200	129,000	11,410	14,520	204	150	70	42		
LIC 318	6-018-300-101-0	D-680	154,840	193,550	17,115	21,780	306	225	105	63	6.00	(152)
LIC 121	6-021-100-100-0	D-127	69,887	87,359	7,755	9,870	139	107	55	28		
LIC 221	6-021-200-100-0	-200-900-9	139,775	174,719	15,510	19,740	277	213	111	55		
LIC 321	6-021-300-100-0	D-783	209,662	262,078	23,265	29,610	416	320	166	83	6.00	(152)
LIC 124H	6-025-100-100-0	D-347	122,960	153,700	13,575	17,275	243	180	90	40		
LIC 224H	6-025-200-100-0	-200-900-9	245,920	307,400	27,150	34,550	487	360	180	80		
LIC 324H	6-025-300-201-0	-300-900-9	368,880	461,100	40,725	51,825	729	540	270	120	6.50	(165)
LIC 127	6-027-100-100-0	-100-900-9	137,509	171,886	15,260	19,420	273	210	109	55		
LIC 227	6-027-200-100-0	-200-900-9	275,018	343,773	30,520	38,840	546	420	218	109		
LIC 327	6-027-300-100-0	D-689	412,527	515,659	45,780	58,260	819	630	327	164	7.25	(184)
LIC 130H	6-031-100-100-0	B-195	261,600	327,000	29,630	37,710	519	380	190	100		
LIC 230H	6-031-200-349-0	-200-900-9	523,200	654,000	59,260	75,420	1,038	760	380	200		
LIC 330H	6-031-300-104-0	-300-902-9	784,800	981,000	88,890	113,130	1,557	1,140	570	300	9.00	(229)
LIC 136	6-036-100-100-0	-100-900-9	406,400	508,000	44,920	57,175	805	600	295	165		
LIC 236	6-036-200-100-0	D-570	812,800	1,016,000	89,840	114,350	1,610	1,200	590	330		
LIC 336	6-036-300-100-0	-300-900-9	1,219,200	1,524,000	134,760	171,525	2,415	1,800	885	495	14.00	(355)
LIC 142	6-042-100-303-0	-100-900-9	580,800	726,000	69,160	81,660	1,150	850	425	235		
LIC 242	6-042-200-309-0	-200-900-9	1,162,240	1,452,800	128,320	163,320	2,300	1,700	850	470		
LIC 342	6-042-300-302-0	-300-303-9	1,742,400	2,178,000	192,480	244,980	3,450	2,550	1,275	705	18.00	(455)
LIC 148	6-048-100-300-0	-100-901-9	1,122,000	1,402,500	118,800	151,200	2,225	1,600	800	455		
LIC 248	6-048-200-300-0	-200-906-9	2,244,000	2,805,000	237,600	302,400	4,450	3,200	1,600	915		
LIC 348	6-048-300-110-0	-300-900-9	3,366,000	4,207,500	356,400	453,600	6,675	4,800	2,400	1,365	19.00	(480)
LIC 260	6-060-200-302-0	-200-907-9	4,760,000	5,950,000	473,000	602,000	9,440	5,950	3,470	1,940		
LIC 360	6-060-300-201-0	-300-901-9	7,140,000	8,925,000	709,000	902,300	14,160	8,925	5,205	2,910		
LIC 460	6-060-400-300-0	E-236	14,280,000	17,850,000	946,000	1,204,000	18,880	11,900	6,940	3,880		

Maximum Air Pressure is 130 PSI / 9 BAR.

Air Tube Disc Clutches and Brakes

Low Inertia Clutches Specifications

Model Size ATD-	Recom- mended Clearance in.	Balance Speed RPM	Airtube Type		Swept Area in. ²	Airtube Volume in. ³ /(cm ³)		Total Clutch				Hub & Center Plate			
			Reg- Speed RPM	High Speed RPM*		New	Worn	Wt.		WR ² / J=mr ²		Wt.		WR ² / J=mr ²	
								lb.	(kg)	lb.ft. ²	(kgm ²)	lb.	(kg)	lb.ft. ²	(kgm ²)
LIC 106	1/16-3/32				39	1.8	11.9	27.5	(12)	2.5	(0.105)	6.40	(2.9)	0.24	(0.010)
LIC 206	3/32-5/32	2,225	1,800	2,600*	78	(30)	(195)	40.5	(18)	3.3	(0.139)	12.17	(5.5)	0.46	(0.019)
LIC 108	1/16-1/8				56			62	(28)	7.5	(0.315)	11	(5.0)	0.54	(0.023)
LIC 208	3/32-5/32	1,675	1,750	3,000*	112	3.4	18.3	70	(32)	8.5	(0.357)	19	(8.6)	1.00	(0.042)
LIC 308	1/8-3/16				168	(56)	(300)	92	(42)	99	(4.174)	28	(12.7)	2.00	(0.084)
LIC 111	1/16-1/8				114			133	(60)	27	(1.14)	23	(10.4)	2.30	(0.097)
LIC 211	3/32-5/32	1,200	1,400	2,800*	228	5.5	30.5	170	(77)	34	(1.43)	45	(20.4)	4.50	(0.190)
LIC 311	1/8-3/16				342	(90)	(500)	208	(94)	52	(2.19)	121	(54.9)	7.00	(0.295)
LIC 114	1/16-1/8				158			184	(83)	56	(2.36)	46	(20.9)	5.7	(0.240)
LIC 214	3/32-5/32	950	1,200	2,200*	316	7.6	42.7	233	(106)	70	(2.95)	77	(34.9)	11.0	(0.464)
LIC 314	1/8-3/16				474	(125)	(700)	292	(132)	80	(3.37)	121	(54.9)	16.7	(0.704)
LIC 116	1/16-1/8				228			257	(117)	103	(4.34)	59	(26.8)	10.2	(0.430)
LIC 216	3/32-5/32	835	1,200	2,000*	455	9.8	56.1	326	(148)	125	(5.27)	106	(48.1)	19.6	(0.826)
LIC 316	1/8-3/16				683	(161)	(919)	358	(162)	125	(5.27)	151	(68.5)	29.6	(1.248)
LIC 118	1/16-1/8				264			311	(141)	158	(6.66)	73	(33.1)	15.0	(0.632)
LIC 218	3/32-5/32	750	1,000	2,000*	528	15.3	85.4	377	(171)	183	(7.72)	120	(54.4)	28.8	(1.214)
LIC 318	1/8-3/16				792	(251)	(1,400)	472	(214)	219	(9.23)	180	(81.6)	43.2	(1.821)
LIC 121	3/32-5/32				362			467	(212)	303	(12.77)	116	(52.6)	32	(1.35)
LIC 221	1/8-3/16	650	900	1,650*	724	18.3	97.6	582	(264)	356	(15.01)	198	(89.8)	61	(2.57)
LIC 321	5/32-7/32				1,086	(300)	(1,599)	730	(331)	450	(18.97)	272	(123.4)	92	(3.88)
LIC 124H	3/32-5/32				574			637	(289)	468	(19.73)	132	(60.0)	56	(2.4)
LIC 224H	1/8-3/16	550	700	1,400*	1,148	29.9	159	830	(376)	618	(26.05)	260	(117.9)	109	(4.6)
LIC 324H	5/32-7/32				1,722	(490)	(2,606)	1,025	(465)	735	(31.00)	379	(172.0)	160	(6.8)
LIC 127	3/32-5/32				730			770	(349)	706	(29.8)	187	(84.8)	98	(4.1)
LIC 227	1/8-3/16	500	700	1,400*	1,460	29.9	159	950	(431)	862	(36.3)	322	(146.1)	193	(8.1)
LIC 327	5/32-7/32				2,190	(490)	(2,606)	1,112	(504)	969	(40.9)	555	(251.7)	285	(12.0)
LIC 130H	3/32-5/32				827			1,035	(469)	1,170	(49.3)	298	(135.2)	189	(8.0)
LIC 230H	1/8-3/16	450	600	1,100*	1,654	58.6	311	1,411	(640)	1,552	(65.4)	546	(247.7)	370	(15.6)
LIC 330H	5/32-7/32				2,481	(960)	(5,096)	1,751	(794)	1,788	(75.4)	810	(367.4)	477	(20.1)
LIC 136	3/32-5/32				1,150			1,455	(660)	2,368	(99.8)	461	(209.1)	372	(15.7)
LIC 236	1/8-3/16	375	600	900*	2,300	110	415	1,992	(904)	3,247	(136.9)	708	(321.1)	725	(30.6)
LIC 336	5/32-7/32				3,450	(1,803)	(6,801)	2,610	(1,184)	4,057	(171.0)	1,134	(514.4)	1,091	(46.0)
LIC 142	5/32-7/32				1,400			1,967	(892)	4,721	(199)	680	(308)	705	(30)
LIC 242	3/16-1/4	325	500	800*	2,800	128	488	2,732	(1,239)	5,750	(242)	1,197	(543)	1,385	(58)
LIC 342	7/32-9/32				4,200	(2,098)	(7,997)	3,704	(1,680)	9,191	(387)	1,324	(601)	1,809	(76)
LIC 148	1/8-1/4				2,010			3,158	(1,432)	9,325	(393)	1,101	(499)	1,785	(75)
LIC 248	5/32-7/32	275	400	700*	4,020	217	824	4,700	(2,132)	13,775	(581)	1,942	(881)	3,335	(141)
LIC 348	3/16-5/16				6,030	(3,550)	(13,500)	6,540	(2,966)	18,000	(759)	2,950	(1,338)	4,925	(208)
LIC 260	3/16-5/16				7,230			9,453	(4,288)	48,733	(2,055)	2,567	(1,164)	7,077	(298)
LIC 360	1/4-3/8	225	320	550*	10,845	513	1,788	11,643	(5,281)	57,286	(2,415)	3,870	(1,755)	10,615	(448)
LIC 460	5/16-7/16				14,460	(8,407)	(29,300)	14,500	(6,577)	68,980	(2,908)	5,700	(2,585)	15,070	(635)

* Consult Factory for Special Assembly Number.

Air Tube Disc Clutches and Brakes

Air System Data

PSI pressure

Inflation

Clutch air pressure during inflation can be closely estimated by the following:

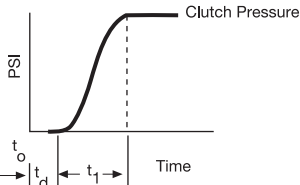

$$t_1 = \left(\frac{3}{K}\right)^{\frac{1}{U}} \text{ sec.} = \text{Time to 95\% Full Inflation}$$

$$\text{Clutch pressure} = P_1 \left(1 - \frac{1}{e^{Kt^U}}\right) \text{ PSI (inflation)}$$

This equation is accurate from 5% up to 95% P_1 .

P_1 = Line pressure to clutch PSI

K and U = coefficients for specific clutch and air pressure from Specification Table

e = Napierian base log

t_o = Time at initiation of signal for inflation sec.

t_d = Time delay of air system – sec.

Exhaust

Clutch air pressure during exhaust can be closely estimated by the following:

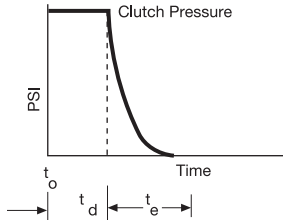

$$\text{Clutch pressure} = (P_1) (R) (E-t)^V \text{ PSI (exhaust)}$$

R, E and V = coefficients for specific clutch and air pressure from Specification Table

t_e = Time to exhaust = E from Specification Table

t = Time variable – seconds. In the exhaust equation “t” cannot exceed the value of “E” sec.

Overlap

A typical clutch-brake torque curve for a single backshaft press (cyclic application) would appear as shown below.

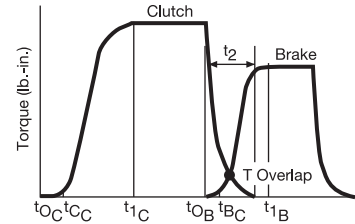

Time (sec.)

t_{oC} = time at which disengaged clutch receives signal

t_{cC} = time of clutch engagement

t_{1C} = time of clutch full inflation

t_{oB} = time at which disengaged brake receives signal

t_{bC} = time of brake engagement

t_{1B} = time of brake full exhaust

t_2 = overlap time at which clutch and brake are both engaged

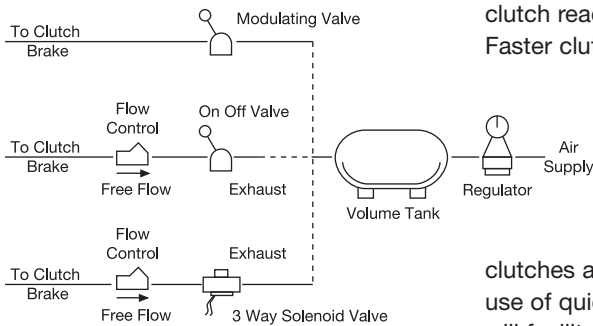

Shown are some of the air systems used on Wichita clutches. These systems are acceptable for remote operation where clutch reaction time is not important.

Faster clutch reaction time is accomplished as indicated in the diagram by locating the flow control valve, if required, and the solenoid valve as close as possible to the roto-coupling. Where clutches are located on long shafts, the use of quick release valves on the clutch will facilitate faster clutch response.

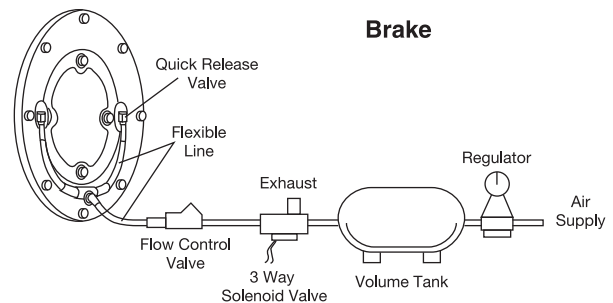
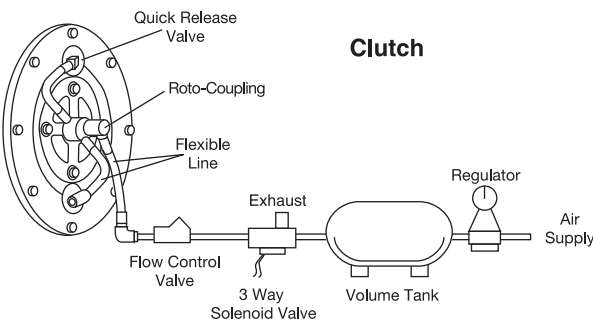

Air Tube Disc Clutches and Brakes

Low Inertia and Very Low Inertia Clutches and Brakes

Inflation Coefficients

Model Size ATD-	Inflation Coefficients Operating Air Pressure					
	50 PSI		75 PSI		100 PSI	
	K	U	K	U	K	U
108	15,800	2.2	7,100	2	265	1.2
208	15,800	2.2	7,100	2	265	1.2
111	890	1.7	880	1.6	5,100	2.2
211	890	1.7	880	1.6	5,100	2.2
114	980	2.3	980	2.3	980	2.3
214	980	2.3	980	2.3	980	2.3
118	9,600	3.1	1,560	2.4	9,600	3.1
218	9,600	3.1	1,560	2.4	9,600	3.1
124H	145	1.8	90	1.6	87	1.6
224H	145	1.8	90	1.6	87	1.6
130H	185	2	150	2	93	1.8
230H	185	2	150	2	93	1.8
136	170	2	250	2.2	160	2
236	170	2	250	2.2	160	2
142	115	2	125	2	111	2
242	115	2	125	2	111	2
148	25	1.6	22	1.6	26	1.8
248	25	1.6	22	1.6	26	1.8
260	28	1.8	22	1.8	20	1.8
360	28	1.8	22	1.8	20	1.8

Exhaust Coefficients

Model Size ATD-	Exhaust Coefficients Operating Air Pressure								
	50 PSI			75 PSI			100 PSI		
	R	E	V	R	E	V	R	E	V
108	60	.016	1.0	525	.02	1.6	240	.02	1.4
208	60	.016	1.0	525	.02	1.6	240	.02	1.4
111	1,000	.032	2	8,200	.04	2.8	4,930	.048	2.8
211	1,000	.032	2	8,200	.04	2.8	4,930	.048	2.8
114	720	.072	2.5	800	.069	2.5	1,840	.082	3
214	720	.072	2.5	800	.069	2.5	1,840	.082	3
118	44	.068	1.4	40	.072	1.4	34	.08	1.4
218	44	.068	1.4	40	.072	1.4	34	.08	1.4
124H	360	.096	2.5	240	.112	2.5	270	.136	2.8
224H	360	.096	2.5	240	.112	2.5	270	.136	2.8
130H	120	.104	2.1	140	.128	2.4	146	.158	2.7
230H	120	.104	2.1	140	.128	2.4	146	.158	2.7
136	124	.112	2.2	92	.128	2.2	76	.152	2.3
236	124	.112	2.2	92	.128	2.2	76	.152	2.3
142	132	.12	2.3	89	.144	2.3	61	.168	2.3
242	132	.12	2.3	89	.144	2.3	61	.168	2.3
148	20	.224	2	20	.256	2.2	19	.308	2.5
248	20	.224	2	20	.256	2.2	19	.308	2.5
260	24	.264	2.4	10	.367	2.3	9.9	.352	2.2
360	24	.264	2.4	10	.367	2.3	9.9	.352	2.2

Air Tube Disc Clutches and Brakes

Low Inertia Clutches

Sizes 8-36

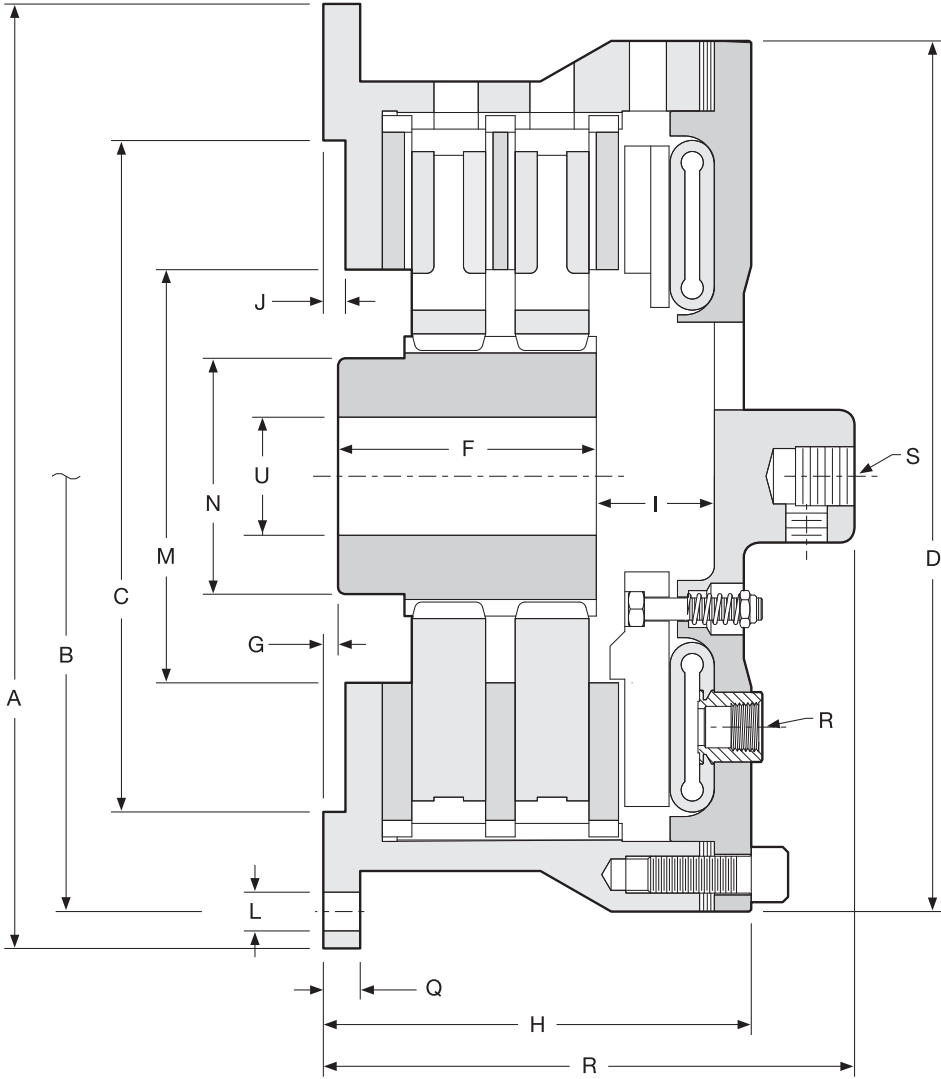

Air Tube Disc Clutches and Brakes

Low Inertia Clutches

Sizes 8-36

Dimensions: inches (mm)

Model Size ATD-	A	B Hole Circle	C Pilot	D	E	F	G	H
LIC 108	12.13	11.125	8.375 / 8.378	11.13	6.31 (160.3)	2.00 (50.8)	.25 (6.4)	4.56 (115.8)
LIC 208	(308.1)	(282.58)	(212.73 / 212.80)	(282.7)	7.69 (195.3)	3.25 (82.6)	.31 (7.9)	5.94 (150.9)
LIC 111	16.00	14.750	11.375 / 11.378	14.75	7.25 (184.2)	2.75 (69.9)	.13 (3.3)	5.50 (139.7)
LIC 211	(406.4)	(374.65)	(288.93 / 289.00)	(374.7)	9.00 (228.6)	4.38 (111.3)	.25 (6.4)	7.25 (184.2)
LIC 114	18.75	17.500	14.375 / 14.378	17.50	7.56 (192.0)	3.75 (95.3)	.13 (3.3)	6.06 (153.9)
LIC 214	(476.3)	(444.50)	(365.13 / 365.20)	(444.5)	9.38 (238.3)	4.50 (114.3)	.38 (9.7)	7.88 (200.2)
LIC 116					7.81 (198.4)	4.00 (101.6)		6.31 (160.3)
LIC 216	21.25	20.000	16.250 / 16.253	20.00	9.75 (247.7)	4.75 (120.7)	.38 (9.7)	8.25 (209.6)
LIC 316	(539.8)	(508.00)	(412.75 / 412.83)	(508.0)	11.69 (296.9)	6.63 (168.4)		10.19 (258.8)
LIC 118					8.19 (208.0)	4.00 (101.6)		6.69 (169.9)
LIC 218	23.25	22.000	18.250 / 18.253	22.00	10.13 (257.3)	4.75 (120.7)	.44 (11.2)	8.63 (219.2)
LIC 318	(590.6)	(558.80)	(463.55 / 463.63)	(558.8)	12.13 (308.1)	6.50 (165.1)		10.63 (270.0)
LIC 121					8.88 (225.6)	4.00 (101.6)	.75 (19.1)	7.38 (187.5)
LIC 221	27.00	25.500	21.375 / 21.378	24.88	10.94 (277.9)	5.13 (130.3)	.63 (16.0)	9.44 (239.8)
LIC 321	(685.8)	(647.70)	(542.93 / 543.00)	(632.0)	13.25 (336.6)	7.13 (181.1)	.75 (19.1)	11.75 (298.5)
LIC 124H					9.13 (231.9)	4.00 (101.6)	.69 (17.5)	7.63 (193.8)
LIC 224H	30.00	28.750	24.375 / 24.378	29.00	11.38 (289.1)	5.13 (130.3)	.75 (19.1)	9.88 (251.0)
LIC 324H	(762)	(730.25)	(619.13 / 619.20)	(736.6)	13.75 (349.3)	7.50 (190.5)	.75 (19.1)	12.25 (311.2)
LIC 127					9.38 (238.3)	4.50 (114.3)	.75 (19.1)	7.88 (200.2)
LIC 227	32.75	31.500	27.375 / 27.378	31.00	11.88 (301.8)	6.88 (174.8)		10.38 (263.7)
LIC 327	(831.9)	(800.10)	(695.33 / 695.40)	(787.4)	—	—	—	—
LIC 130H					12.5	5.00 (127.0)	.63 (16.0)	8.25 (209.6)
LIC 230H	37.00	35.500	30.375 / 30.3783	34.75	15.94	7.13 (181.1)	1.88 (47.8)	11.69 (296.9)
LIC 330H	(939.8)	(901.70)	(771.53 / 771.60)	(882.7)	—	—	—	—
LIC 136					12.94 (328.7)	5.63 (143.0)		9.44 (239.8)
LIC 236	43.50	42.000	36.375 / 36.378	41.00	16.63 (422.4)	9.00 (228.6)	.63 (16.0)	12.75 (323.9)
LIC 336	(1,104.9)	(1,066.80)	(923.93 / 924.00)	(1,041.4)	19.88 (505.0)	12.38 (314.5)		16.38 (416.1)

Dimensions: inches (mm)

Model Size ATD-	I	J	L		M	N	Q	R		S	U	
			No. -	Size				No. -	Size		Min.	Max.
LIC 108	1.78 (45.2)	.25			5.38	3.50	.50				1.00	2.00
LIC 208	1.88 (47.8)	(6.4)	6 -	17/32 (13.5)	(136.7)	(88.9)	(12.7)	2 -	1/2 NPT	1"-14NF	(25)	(50.8)
LIC 111		.38	6 -	11/16 (17.5)	7.00	4.00	.63	2 -	1/2 NPT	1"-14NF	1.00	2.50
LIC 211	2.00 (50.8)	(9.7)	6 -	21/32 (16.7)	(177.8)	(101.6)	(16.0)	2 -	1/2 NPT	1"-14NF	(25)	(63.5)
LIC 114	1.44 (36.6)	.38	8 -	21/32 (16.7)	9.44	5.50	.63	2 -	1/2 NPT	1"-14NF	1.38	3.50
LIC 214	2.13 (54.1)	(9.7)	8 -	21/32 (16.7)	(239.8)	(139.7)	(16.0)	2 -	1/2 NPT	1"-14NF	(35.1)	(88.9)
LIC 116	1.13 (28.7)											
LIC 216	2.31 (58.7)	.38	12 -	21/32 (16.7)	10.50	6.00	.63	2 -	1/2 NPT	1"-14NF	1.38	4.00
LIC 316	2.31 (58.7)	(9.7)	12 -	21/32 (16.7)	(266.7)	(152.4)	(16.0)	2 -	1/2 NPT	1"-14NF	(35.1)	(101.6)
LIC 118	1.25 (31.8)											
LIC 218	2.50 (63.5)	.38	12 -	21/32 (16.7)	12.50	7.00	.63	3 -	1/2 NPT	1"-14NF	2.00	4.75
LIC 318	2.75 (69.9)	(9.7)	12 -	21/32 (16.7)	(317.5)	(177.8)	(16.0)	3 -	1/2 NPT	1"-14NF	(50.8)	(120.7)
LIC 121	1.63 (41.4)											
LIC 221	2.68 (68.1)	.31	12 -	21/32 (16.7)	14.50	9.00	.75	3 -	1/2 NPT	1"-14NF	2.00	6.00
LIC 321	2.75 (69.9)	(7.9)	12 -	21/32 (16.7)	(368.3)	(228.6)	(19.1)	3 -	1/2 NPT	1"-14NF	(50.8)	(152.4)
LIC 124H	1.75 (44.5)											
LIC 224H	2.94 (74.7)	.25	12 -	21/32 (16.7)	14.50	9.00	.75	3 -	1/2 NPT	1"-14NF	2.00	6.00
LIC 324H	2.88 (73.2)	(6.4)	12 -	21/32 (16.7)	(368.3)	(228.6)	(19.1)	3 -	1/2 NPT	1"-14NF	(50.8)	(152.4)
LIC 127	1.38 (35.1)	.25										
LIC 227	1.50 (38.1)	(6.4)	16 -	21/32 (16.7)	16.25	9.00	.75	3 -	1/2 NPT	1"-14NF	2.50	6.50
LIC 327	—	—	16 -	21/32 (16.7)	(412.8)	(228.6)	(19.1)	3 -	1/2 NPT	1"-14NF	(63.5)	(165.1)
LIC 130H	1.81 (46.0)											
LIC 230H	1.88 (47.8)	.25	18 -	25/32 (19.8)	19.25	10.00	.75	4 -	1/2 NPT	1" NPT	2.50	7.25
LIC 330H	—	(6.4)	18 -	25/32 (19.8)	(489)	(254)	(19.1)	4 -	1/2 NPT	1" NPT	(63.5)	(184.2)
LIC 136	1.38 (35.1)											
LIC 236	1.63 (41.4)	.25	18 -	25/32 (19.8)	23.63	12.00	.88	4 -	1/2 NPT	1" NPT	6.00	9.00
LIC 336	1.75 (44.5)	(6.4)	18 -	25/32 (19.8)	(600.2)	(304.8)	(22.4)	4 -	1/2 NPT	1" NPT	(152.4)	(228.6)

Note: For mounting, use socket head capscrews conforming to the ASTM-574-97a. (Consult factory for drawing before final layout.)

Air Tube Disc Clutches and Brakes

Low Inertia Clutches

Sizes 6, 42-60

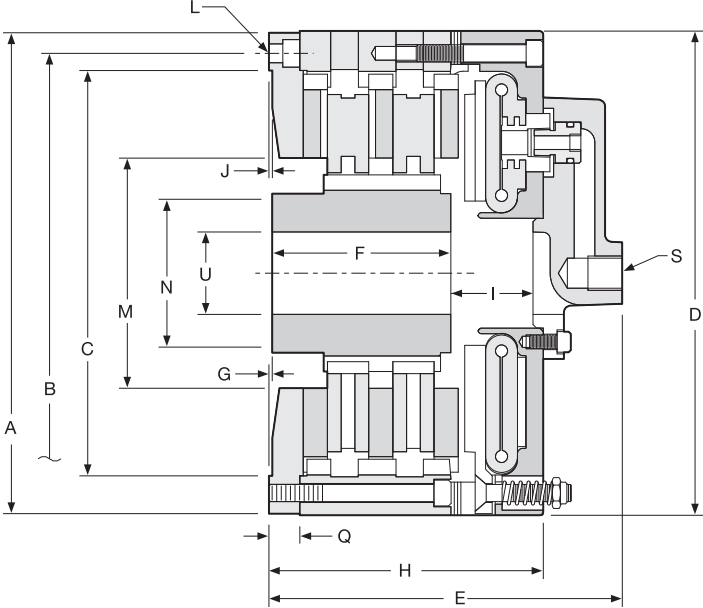

Size 6

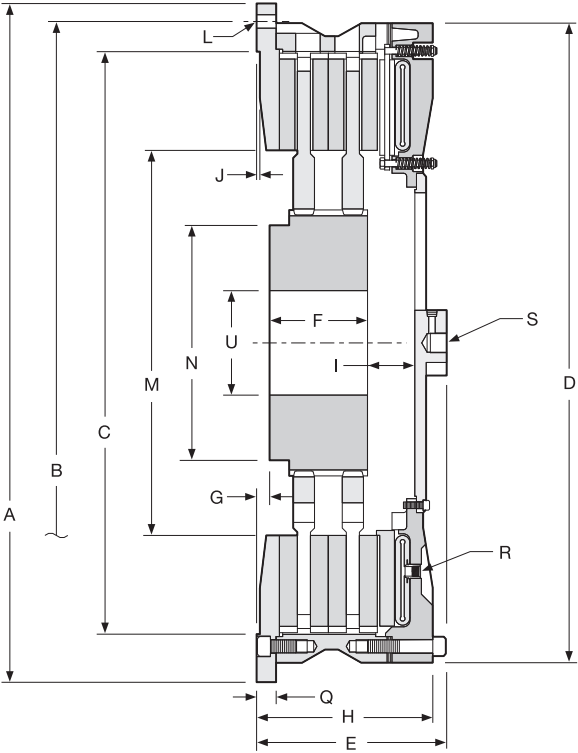

Size 42-60

Air Tube Disc Clutches and Brakes

Low Inertia Clutches

Sizes 6, 42-60

Dimensions: inches (mm)

Model Size ATD-	A	B Hole Circle	C Pilot	D	E	F	G	H
LIC 106	8.75	8.000	7.377 / 7.379	8.81	5.19 (131.8)	2.00 (50.8)	0.00 (0.0)	3.75 (95.3)
LIC 206	(222.3)	(203.20)	(187.38 / 187.43)	(223.8)	6.43 (163.3)	3.25 (82.6)	0.06 (1.5)	5.00 (127.0)
LIC 142	52.00	49.250	44.625 / 44.628	49.00	10.81 (274.6)	5.63 (143.0)	1.00 (25.40)	9.75 (247.7)
LIC 242	(1,320.8)	(1,250.95)	(1,133.48 / 1,133.55)	(1,244.6)	14.56 (369.8)	7.50 (190.5)		13.5 (342.9)
LIC 148	61.00	58.000	52.000 / 52.005	56.75	14.69 (373.1)	6.00 (152.4)	0.00 (0.0)	10.69 (271.5)
LIC 248	(1,549.4)	(1,473.20)	(1,320.80 / 1,320.93)	(1,441.5)	19.07 (484.4)	8.75 (222.3)	1.00 (25.4)	15.07 (382.8)
LIC 260 ¹					20.30 (515.6)	9.38 (238.3)	0.25 (6.4)	17.99 (456.9)
LIC 360 ¹	70.50	66.500	62.750 / 62.760	70.50	22.00 (558.8)	12.25 (311.2)	0.00 (0.0)	19.63 (498.6)
LIC 460 ¹	(1,790.7)	(1,689.10)	(1,593.85 / 1,594.10)	(1,790.7)	28.25 (717.6)	18.63 (473.2)	0.25 (6.4)	27.13 (689.1)

Dimensions: inches (mm)

Model Size ATD-	I	J	L		M	N	Q	R		S	U	
			No.-	Size				No. -	Size		Min.	Max.
LIC 106	1.56 (39.6)	0.06	4 -	0.34 (8.6)	4.19	2.69	0.56	—	5/8"-11NF	0.60	2.00	
LIC 206	1.50 (38.1)	(1.5)			(106.4)	(68.3)	(14.2)			(15.2)	(50.8)	
LIC 142	1.75 (44.5)	0.25	24 -	1.06 (26.9)	29.50	18.00	1.50	4 - 1/2 NPT	1.5"-12NF	8.00	14.00	
LIC 242	3.63 (92.2)	(6.4)			(749.3)	(457.2)	(38.1)			(203.2)	(355.6)	
LIC 148	3.69 (93.7)	0.25	24 -	1.06 (26.9)	32.00	25.75	1.50	4 - 1/2 NPT	1" NPT	10.00	18.00	
LIC 248	4.32 (109.7)	(6.4)			(812.8)	(654.1)	(38.1)			(254.0)	(457.2)	
LIC 260 ¹	6.17 (156.7)	0.25	24 -	4.5"NC	36.00	27.00	—	6 - 1/2 NPT	2"-12NF	11.00	19.00	
LIC 360 ¹	5.19 (131.8)				(6.4)	(914.4)				(685.8)	(279.4)	(482.6)
LIC 460 ¹	6.38 (162.1)											

¹Less backplate.

NOTE: For mounting, use socket head capscrews conforming to the ASTM-574-97a.
(Consult factory for drawing before final layout.)

Air Tube Disc Clutches and Brakes

Low Inertia Clutch Air Hose Kits

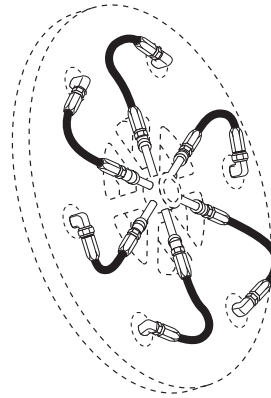
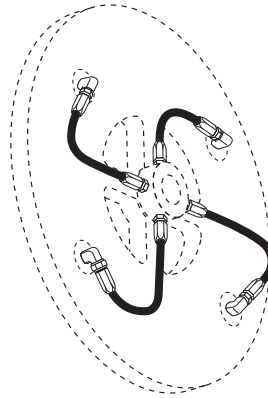
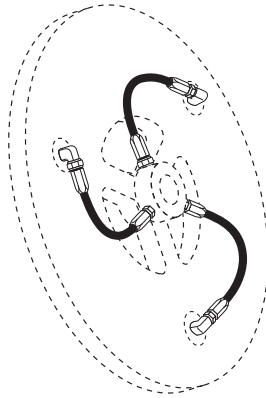
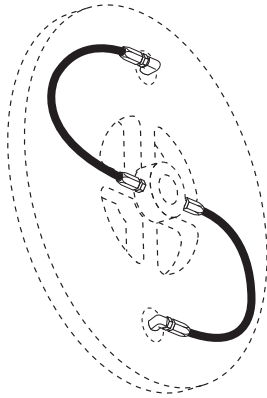

Size	Part Number
8"	8-908-812-200-5 8-908-821-201-5 QRV
11"	8-911-812-201-5 8-911-821-201-5 QRV
14"	8-914-812-200-5 8-914-821-200-5 QRV

Size	Part Number
18"	8-918-812-301-5 8-918-821-300-5 QRV
24"H	8-924-812-300-5 8-924-821-301-5 QRV

Size	Part Number
30"	8-930-812-400-5 8-930-821-400-5 QRV
36"	8-936-821-400-5 QRV
42"	8-942-821-400-5 QRV
48"	8-948-821-400-5 QRV

Size	Part Number
60"	8-960-800-500-7 QRV

Air hose kits contain all necessary parts (fittings, hoses and extensions) to completely plumb the clutch air system.

Optional Quick Release Valves can replace elbows on most units (see page 35).

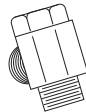

Roto-couplings (see page 35).



Air Tube Disc Clutches and Brakes

Quick Release Valve

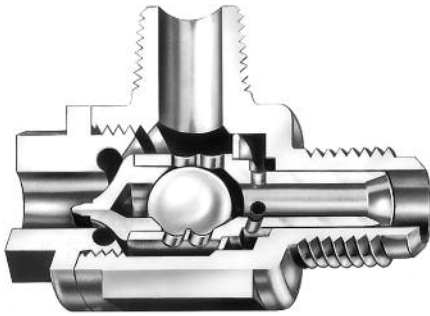

8-263-610-011-1 7/8" - 14 Thread
 8-263-610-021-1 1/2" NPT
 4-263-605-002-0 Optional Muffler

The Wichita Springless Quick Release Valve discharges twice as fast as any other valve tested in our laboratory and is four to five times faster than some common makes of valves.

This valve will close and seal with less than 20 lbs. pressure. Most others require 25 to 30 lbs. to definitely seal. In actual tests, the Wichita Valve made many hundreds of thousands of engagements and disengagements before the slightest leak occurred, or any parts needed replacement. Other valves which were tested required major replacement in fewer than 20,000 cycles.

Quality Material

Body and Cap: High strength aluminum alloy
 Stem: Molded nylon
 Check Valve: Nylon ball
 "O" Ring: Neoprene

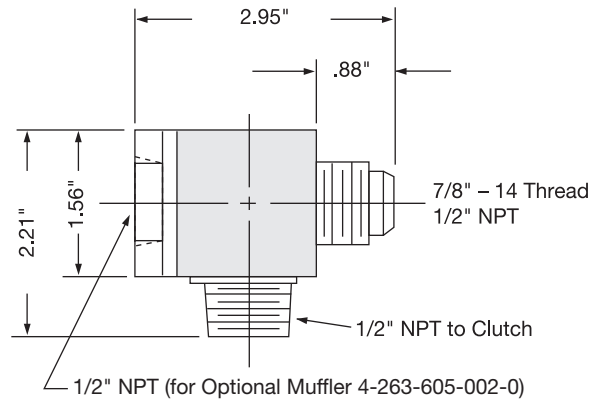

Standard thread arrangement of 1/2" size. 1/2" pipe thread on the tube connection and choice of 1/2" pipe thread, or standard 7/8-14NF thread for flared fitting thread on inlet connection. (Fits standard No. 10 high-pressure hose fitting.)

Roto-couplings

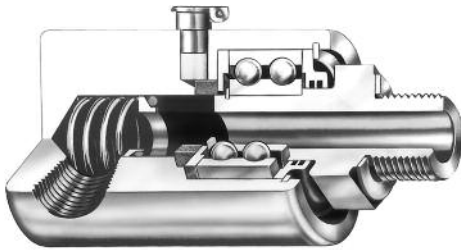

The Wichita Roto-coupling is a device to connect, or couple, a non-rotating air, gas, or fluid line to a rotating shaft.

- Long life, no maintenance.
- Felt seal eliminates bearing contamination.
- Fast, easy installation.

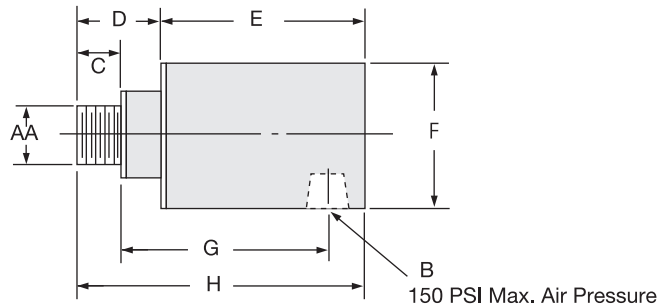

Dimensions: inches

Wichita Part No.	AA	B	C	D	E	F	G	H	Max. RPM
8-240-701-003-1	5/8-18NF	1/4" NPT	.40	1.046	2.250	1.500	2.13	3.297	3500
8-240-705-001-1	1"-14 NF	1/2" NPT	.75	1.250	3.188	2.500	3.00	4.438	3500
8-240-708-001-1	1"-14 NF	3/4" NPT	.75	1.313	4.688	2.875	3.69	5.440	3500
8-240-710-002-1	1-1/2"-12 NF	1" NPT	1.13	1.937	4.875	3.250	3.44	6.812	2500
8-240-712-001-1	2"-12 NF	1-1/2" NPT	1.13	2.813	5.250	4.250	5.38	8.062	2500
8-240-714-001-3	2" NPT	2" NPT	1.50	3.000	7.062	4.625	7.00	10.062	1000
8-240-716-000-3	2-1/2" NPT	2-1/2" NPT	1.88	3.250	9.375	7.000	7.75	12.625	750



Air Tube Disc Clutches and Brakes

Low Inertia Brakes

Specifications

Model Size ATD-	Assembly Number	Drawing Number	Slip Torque Capacity				Duty Factors				Max. Bore Rect. Key	
			lb.in.		Nm		HP/100 RPM					
			80 PSI	100 PSI	5.5 BAR	7 BAR	A	B	C	D	in.	(mm)
LIB 104	7-004-100-803-0	-100-901-9	800	1,000	90	113	1.6	1.2	0.6	0.3	1.00	(25)
LIB 204	7-004-200-801-0	B-518	1,600	2,000	90	225	3.2	2.4	1.2	0.6		
LIB 106	7-006-100-203-0	-100-901-9	3,160	3,950	340	435	6.2	4.4	2.2	1.1	2.00	(50)
LIB 206	7-006-200-200-0	D-465	6,320	7,900	680	870	12.5	8.8	4.4	2.2		
LIB 108	7-008-100-108-0	-100-900-9	5,600	7,000	620	790	11.1	8	4	2		
LIB 208	7-008-200-105-0	-200-900-9	11,200	14,000	1,240	1,580	22.2	16	8	4	2.25	(57)
LIB 308	7-008-300-100-0	D-164	16,800	21,000	1,865	2,375	33.3	24	12	6		
LIB 111	7-011-100-107-0	B-105	12,720	15,900	1,400	1,785	25	18	9	5		
LIB 211	7-011-200-102-0	-200-902-9	25,440	31,800	2,800	3,570	50	36	18	10	2.50	(64)
LIB 311	7-011-300-100-0	B-408	38,160	47,700	4,235	5,390	75	54	27	15		
LIB 114	7-014-100-102-0	-100-900-9	22,100	27,625	2,435	3,100	44	31	16	8		
LIB 214	7-014-200-101-0	-200-902-9	44,200	55,250	4,870	6,200	88	62	32	16	3.50	(89)
LIB 314	7-014-300-102-0	B-288	66,300	82,875	7,355	9,365	132	93	48	24		
LIB 116	7-016-100-100-0	D-461	30,270	37,838	3,360	4,275	60	46	24	12		
LIB 216	7-016-200-100-0	-200-904-9	60,541	75,676	6,720	8,550	120	92	48	24	4.00	(102)
LIB 316	7-016-300-100-0	-300-900-9	90,811	113,514	10,080	12,825	180	139	72	36		
LIB 118	7-018-100-100-0	-100-901-9	51,600	64,500	5,705	7,260	102	75	35	21		
LIB 218	7-018-200-100-0	-200-900-9	103,200	129,000	11,410	14,520	204	150	70	42	4.75	(121)
LIB 318	7-018-300-103-0	D-1218	154,840	193,550	17,115	21,780	306	225	105	63		
LIB 121	7-021-100-100-0	D-373	69,887	87,359	7,755	9,870	139	107	55	28		
LIB 221	7-021-200-100-0	D-267	139,775	174,719	15,510	19,740	277	213	111	55	6.00	(152)
LIB 321	7-021-300-100-0	D-740	209,662	262,078	23,265	29,610	416	320	166	83		
LIB 124H	7-025-100-101-0	D-779	122,960	153,700	13,575	17,275	243	180	90	40		
LIB 224H	7-025-200-101-0	D-371	245,920	307,400	27,150	34,550	487	360	180	80	6.00	(152)
LIB 324H	7-025-300-201-0	-300-900-9	368,880	461,100	40,725	51,825	729	540	270	120		
LIB 127	7-027-100-100-0	D-151	137,509	171,886	15,260	19,420	273	210	109	55		
LIB 227	7-027-200-100-0	D-428	275,018	343,773	30,520	38,840	546	420	218	109	6.50	(165)
LIB 327	6-027-300-100-0	D-689	412,527	515,659	45,780	58,260	819	630	327	164		
LIB 130H	7-031-100-100-0	B-312	261,600	327,000	29,630	37,710	519	380	190	100		
LIB 230H	7-031-200-316-0	B-296	523,200	654,000	59,260	75,420	1,038	760	380	200	7.25	(184)
LIB 330H	7-031-300-304-0	-300-904-9	784,800	981,000	88,890	113,130	1,557	1,140	570	300		
LIB 136	7-036-100-100-0	-100-901-9	406,400	508,000	44,920	57,175	805	600	295	165		
LIB 236	7-036-200-100-0	D-722	812,800	1,016,000	89,840	114,350	1,610	1,200	590	330	9.00	(229)
LIB 336	6-036-300-100-0	-300-900-9	1,219,200	1,524,000	134,760	171,525	2,415	1,800	885	495		
LIB 142	7-042-100-303-0	-100-900-9	580,800	726,000	69,160	81,660	1,150	850	425	235		
LIB 242	7-042-200-311-0	-200-901-9	1,162,240	1,452,800	128,320	163,320	2,300	1,700	850	470	14.00	(355)
LIB 342	6-042-300-302-0	-300-303-9	1,742,400	2,178,000	192,480	244,980	3,450	2,550	1,275	705		
LIB 148	7-048-100-300-0	-100-900-9	1,122,000	1,402,500	118,800	151,200	2,225	1,600	800	455		
LIB 248	7-048-200-300-0	-200-901-9	2,244,000	2,805,000	237,600	302,400	4,450	3,200	1,600	915	18.00	(455)
LIB 348	7-048-300-301-0	-300-900-9	3,366,000	4,207,500	356,400	453,600	6,675	4,800	2,400	1,365		
LIB 260	7-060-200-302-0	-200-901-9	4,760,000	5,950,000	473,000	602,000	9,440	5,950	3,470	1,940		
LIB 360	7-060-300-301-0	-300-901-9	7,140,000	8,925,000	709,000	902,300	14,160	8,925	5,205	2,910	19.00	(480)
LIB 460	6-060-400-300-0	E-236	14,280,000	17,850,000	946,000	1,204,000	18,880	11,900	6,940	3,880		

Maximum Air Pressure is 130 PSI / 9 BAR.

Air Tube Disc Clutches and Brakes

Low Inertia Brakes Specifications

Model Size ATD-	Recom- mended Clearance in.	Balance Speed RPM	Hub & C.P.		Swept Area in. ²	Airtube Volume in. ³ (cm ³)		Total Brake Wt.		Hub & Center Plate Wt. WR ² / J=mr ²			
			Reg- Speed RPM	High Speed RPM*		New	Worn	lb.	(kg)	lb.	(kg)	lb.ft. ²	(kgm ²)
LIB 104	1/32	3,325	5,250	5,250*	17	0.9	3.4	11.0	(7)	1.54	(0.7)	0.021	(0.001)
LIB 204	1/16				34	(14.8)	(56)	14.0	(6)	3.88	(1.8)	0.04	(0.002)
LIB 106	1/16-3/32	2,225	3,800	5,700*	39	1.8	11.9	27.5	(12)	6.40	(2.9)	0.24	(0.010)
LIB 206	3/32-5/32				78	(30)	(195)	40.5	(18)	12.17	(5.5)	0.46	(0.019)
LIB 108	1/16-1/8				56			62	(28)	11	(5.0)	0.54	(0.023)
LIB 208	3/32-5/32	1,675	2,870	4,300*	112	3.4	18.3	70	(32)	19	(8.6)	1.00	(0.042)
LIB 308	1/8-3/16				168	(56)	(300)	87	(39)	28	(12.7)	2.00	(0.084)
LIB 111	1/16-1/8				114			130	(59)	23	(10.4)	2.30	(0.097)
LIB 211	3/32-5/32	1,200	2,090	3,125*	228	5.5	30.5	166	(75)	45	(20.4)	4.50	(0.190)
LIB 311	1/8-3/16				342	(90)	(500)	208	(94)	121	(54.9)	7.00	(0.295)
LIB 114	1/16-1/8				158			184	(83)	46	(20.9)	5.7	(0.240)
LIB 214	3/32-5/32	950	1,640	2,450*	316	7.6	42.7	233	(106)	77	(34.9)	11.0	(0.464)
LIB 314	1/8-3/16				474	(125)	(700)	290	(132)	121	(54.9)	16.7	(0.704)
LIB 116	1/16-1/8				228			254	(115)	59	(26.8)	10.2	(0.430)
LIB 216	3/32-5/32	835	1,430	2,150*	455	9.8	56.1	326	(148)	106	(48.1)	19.6	(0.826)
LIB 316	1/8-3/16				683	(161)	(919)	358	(162)	151	(68.5)	29.6	(1.248)
LIB 118	1/16-1/8				264			311	(141)	73	(33.1)	15.0	(0.632)
LIB 218	3/32-5/32	750	1,270	1,910*	528	15.3	85.4	377	(171)	120	(54.4)	28.8	(1.214)
LIB 318	1/8-3/16				792	(251)	(1,400)	461	(209)	180	(81.6)	43.2	(1.821)
LIB 121	3/32-5/32				362			460	(209)	116	(52.6)	32	(1.35)
LIB 221	1/8-3/16	650	1,090	1,650*	724	18.3	97.6	575	(261)	198	(89.8)	61	(2.57)
LIB 321	5/32-7/32				1,086	(300)	(1,599)	723	(328)	312	(141.5)	122	(5.14)
LIB 124H	3/32-5/32				574			618	(280)	132	(60.0)	56	(2.4)
LIB 224H	1/8-3/16	550	950	1,410*	1,148	29.9	159	840	(381)	260	(117.9)	110	(4.6)
LIB 324H	5/32-7/32				1,722	(490)	(2,606)	1,025	(465)	379	(172.0)	160	(6.8)
LIB 127	3/32-5/32				730			760	(345)	187	(84.8)	98	(4.1)
LIB 227	1/8-3/16	500	850	1,250*	1,460	29.9	159	924	(419)	329	(149.2)	191	(8.1)
LIB 327	5/32-7/32				2,190	(490)	(2,606)	1,112	(504)	555	(251.7)	285	(12.0)
LIB 130H	3/32-5/32				827			972	(441)	298	(135.2)	189	(8.0)
LIB 230H	1/8-3/16	450	765	1,130*	1,654	58.6	311	1,350	(612)	546	(247.7)	370	(15.6)
LIB 330H	5/32-7/32				2,481	(960)	(5,096)	1,751	(794)	810	(367.4)	477	(20.1)
LIB 136	3/32-5/32				1,150			1,388	(630)	461	(209.1)	372	(15.7)
LIB 236	1/8-3/16	375	640	950*	2,300	110	415	1,993	(904)	708	(321.1)	725	(30.6)
LIB 336	5/32-7/32				3,450	(1,803)	(6,801)	2,610	(1,184)	1,134	(514.4)	1,091	(46.0)
LIB 142	5/32-7/32				1,400			1,967	(892)	680	(308)	705	(30)
LIB 242	3/16-1/4	325	545	805*	2,800	128	488	2,732	(1,239)	1,197	(543)	1,385	(58)
LIB 342	7/32-9/32				4,200	(2,098)	(7,997)	3,704	(1,680)	1,324	(601)	1,809	(76)
LIB 148	1/8-1/4				2,010			3,158	(1,432)	1,101	(499)	1,785	(75)
LIB 248	5/32-7/32	275	475	705*	4,020	217	824	4,700	(2,132)	1,942	(881)	3,335	(141)
LIB 348	3/16-5/16				6,030	(3,550)	(13,500)	6,540	(2,966)	2,950	(1,338)	4,925	(208)
LIB 260	3/16-5/16				7,230			9,453	(4,288)	2,567	(1,164)	7,077	(298)
LIB 360	1/4-3/8	225	380	575*	10,845	513	1,788	11,643	(5,281)	3,870	(1,755)	10,615	(448)
LIB 460	5/16-7/16				14,460	(8,407)	(29,300)	14,500	(6,577)	5,700	(2,585)	15,070	(635)

* Consult Factory for Special Assembly Number.

Air Tube Disc Clutches and Brakes

Low Inertia Brakes

Sizes 8-36

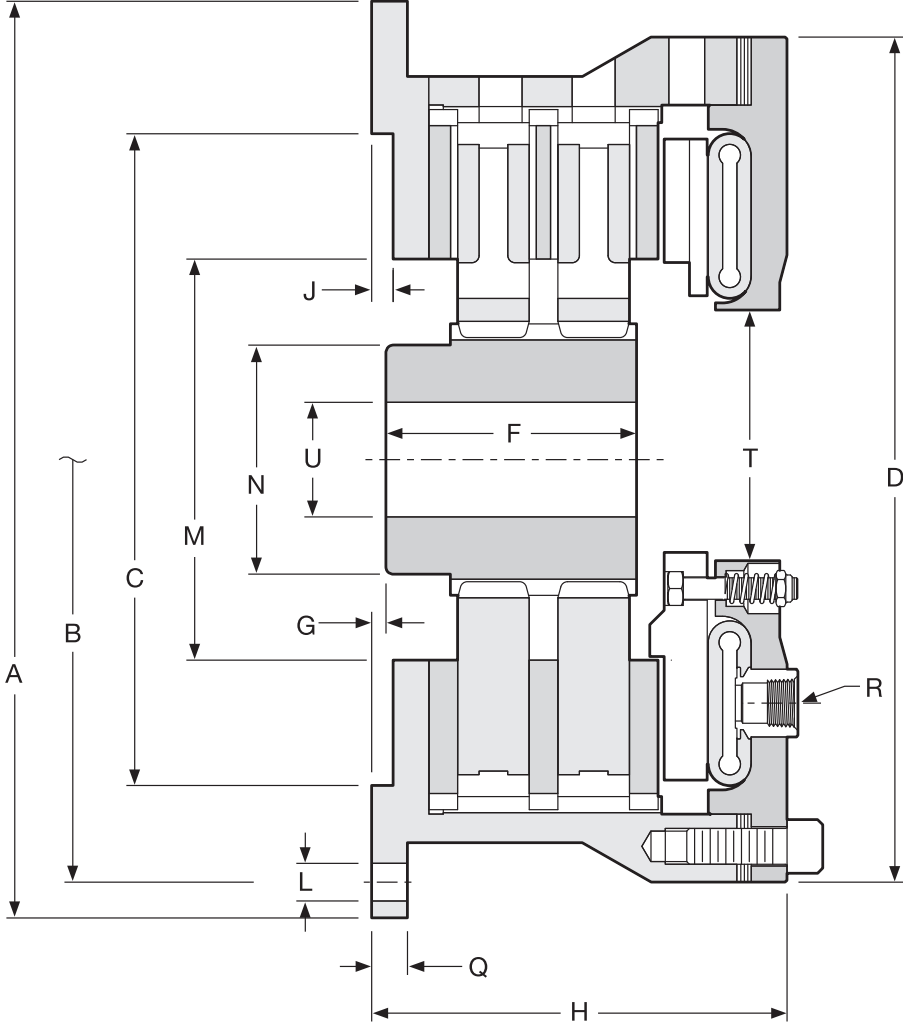

Air Tube Disc Clutches and Brakes

Low Inertia Brakes

Sizes 8-36

Dimensions: inches (mm)

Model Size ATD-	A	B Hole Circle	C Pilot	D	F	G	H
LIB 108	12.13	11.125	8.375 / 8.378	11.13	2.00 (50.8)	.25	4.56 (115.8)
LIB 208	(308.1)	(282.58)	(212.73 / 212.80)	(282.7)	3.25 (82.6)	(6.4)	5.94 (150.9)
LIB 111	16.00	14.750	11.375 / 11.378	14.75	2.75 (69.9)	.13 (3.3)	5.44 (138.2)
LIB 211	(406.4)	(374.65)	(288.93 / 289.00)	(374.7)	4.38 (111.3)	.25 (6.4)	7.19 (182.6)
LIB 114	18.75	17.500	14.375 / 14.378	17.50	3.75 (95.3)	.13 (3.3)	6.06 (153.9)
LIB 214	(476.3)	(444.50)	(365.13 / 365.20)	(444.5)	4.50 (114.3)	.38 (9.7)	8.00 (203.2)
LIB 116					4.00 (101.6)		6.31 (160.3)
LIB 216	21.25	20.000	16.250 / 16.253	20.00	4.75 (120.7)	0.38 (9.7)	8.25 (209.6)
LIB 316	(539.8)	(508.00)	(412.75 / 412.83)	(508.0)	6.63 (168.4)		10.19 (258.8)
LIB 118					4.00 (101.6)		6.69 (169.9)
LIB 218	23.25	22.000	18.250 / 18.253	22.00	4.75 (120.7)	0.44 (11.2)	8.63 (219.2)
LIB 318	(590.6)	(558.80)	(463.55 / 463.63)	(558.8)	6.50 (165.1)		10.63 (270.0)
LIB 121					4.00 (101.6)		7.38 (187.5)
LIB 221	27.00	25.500	21.375 / 21.378	24.88	5.13 (130.3)	.75 (19.1)	9.31 (236.5)
LIB 321	(685.8)	(647.70)	(542.93 / 543.00)	(632.0)	7.13 (181.1)		11.75 (298.5)
LIB 124H					4.00 (101.6)	.69 (17.5)	7.63 (193.8)
LIB 224H	30.00	28.750	24.375 / 24.378	29.00	5.13 (130.3)	.75 (19.1)	9.94 (252.5)
LIB 324H	(762)	(730.25)	(619.13 / 619.20)	(736.6)	7.50 (190.5)	.75 (19.1)	12.25 (311.2)
LIB 127					4.50 (114.3)		7.88 (200.2)
LIB 227	32.75	31.500	27.375 / 27.378	31.00	6.88 (174.8)	0.75 (19.1)	10.38 (263.7)
LIB 327	(831.9)	(800.10)	(695.33 / 695.40)	(787.4)	—	—	—
LIB 130H					5.00 (127.0)	.63 (16.0)	8.38 (212.9)
LIB 230H	37.00	35.500	30.375 / 30.378	34.75	7.13 (181.1)	1.88 (47.8)	11.81 (300.0)
LIB 330H	(939.8)	(901.70)	(771.53 / 771.60)	(882.7)	11.88 (301.8)	.63 (16.0)	15.31 (388.9)
LIB 136	43.50	42.000	36.375 / 36.378	41.00	5.63 (143.0)	0.63	9.50 (241.3)
LIB 236	(1,104.9)	(1,066.80)	(923.93 / 924.00)	(1,041.4)	9.00 (228.6)	(16.0)	12.88 (327.2)

Dimensions: inches (mm)

Model Size ATD-	J	L		M	N	Q	R		T	U	
		No. -	Size				No. -	Size		Min.	Max.
LIB 108	0.25	6 -	17/32 (13.5)	5.38	3.50	0.50	2 -	1/2 NPT	2.25	1.00	2.00
LIB 208	(6.4)			(136.7)	(88.9)	(12.7)				(25)	(50.8)
LIB 111	0.38	6 -	21/32 (16.7)	7.00	4.00	0.63	2 -	1/2 NPT	3.25	1.00	2.50
LIB 211	(9.7)		11/16 (17.5)	(177.8)	(101.6)	(16.0)				(25)	(63.5)
LIB 114	0.38	8 -	21/32 (16.7)	9.44	5.50	0.63	2 -	1/2 NPT	5.06	1.38	3.50
LIB 214	(9.7)			(239.8)	(139.7)	(16.0)				(35.1)	(88.9)
LIB 116											
LIB 216	0.38	12 -	21/32 (16.7)	10.50	6.00	0.63	2 -	1/2 NPT	6.13	1.38	4.00
LIB 316	(9.7)			(266.7)	(152.4)	(16.0)				(35.1)	(101.6)
LIB 118											
LIB 218	0.38	12 -	21/32 (16.7)	12.50	7.00	0.63	3 -	1/2 NPT	7.75	2.00	4.75
LIB 318	(9.7)			(317.5)	(177.8)	(16.0)				(50.8)	(120.7)
LIB 121											
LIB 221	0.31	12 -	21/32 (16.7)	14.50	9.00	.75	3 -	1/2 NPT	9.25	2.00	6.00
LIB 321	(7.9)			(368.3)	(228.6)	(19.1)				(50.8)	(152.4)
LIB 124H											
LIB 224H	0.25	12 -	21/32 (16.7)	14.50	9.00	.75	3 -	1/2 NPT	13.25	2.00	6.00
LIB 324H	(6.4)			(368.3)	(228.6)	(19.1)				(50.8)	(152.4)
LIB 127											
LIB 227	0.25	16 -	21/32 (16.7)	16.25	9.00	.75	3 -	1/2 NPT	13.25	2.50	6.50
LIB 327	(6.4)			(412.8)	(228.6)	(19.1)				(63.5)	(165.1)
LIB 130H											
LIB 230H	0.25	18 -	25/32 (19.8)	19.25	10.00	.75	4 -	1/2 NPT	15.00	2.50	7.25
LIB 330H	(6.4)			(489)	(254)	(19.1)				(63.5)	(184.2)
LIB 136	0.25	18 -	13/16 (20.6)	23.63	12.00	.88	4 -	1/2 NPT	22.75	6.00	9.00
LIB 236	(6.4)		25/32 (19.8)	(600.2)	(304.8)	(22.4)				(152.4)	(228.6)

Note: For mounting, use socket head capscrews conforming to the ASTM-574-97a.
(Consult factory for drawing before final layout.)

B

Air Tube Disc Clutches and Brakes

Low Inertia Brakes

Sizes 6, 42-60

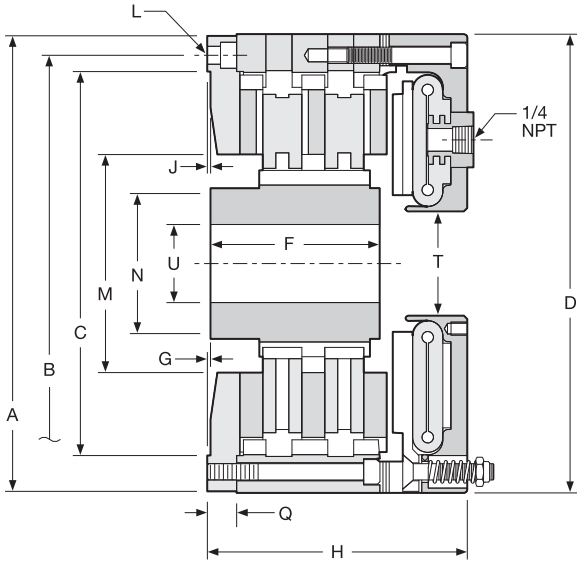

Size 6

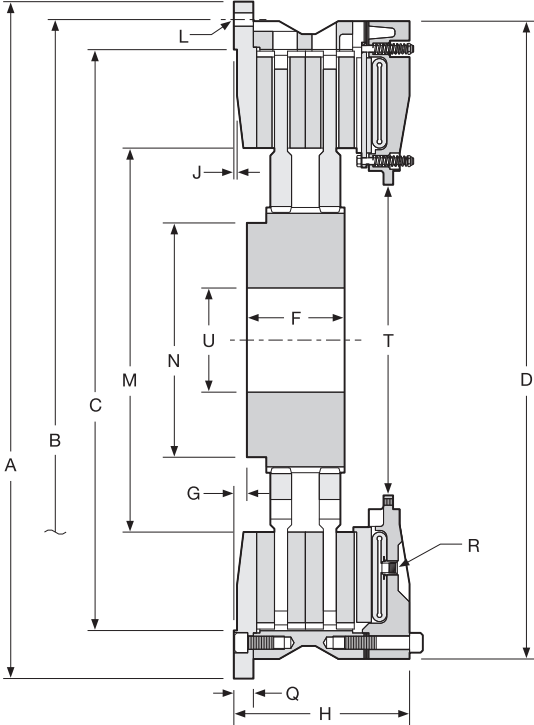

Sizes 42-60

Air Tube Disc Clutches and Brakes

Low Inertia Brakes

Sizes 6, 42-60

Dimensions: inches (mm)

Model Size ATD-	A	B Hole Circle	C Pilot	D	F	G	H
LIB 106	8.75	8.000	7.377 / 7.379	8.81	2.00 (50.8)	0.00 (0.0)	3.75 (95.3)
LIB 206	(222.3)	(203.20)	(187.38 / 187.43)	(223.8)	3.25 (82.6)	0.06 (1.5)	5.00 (127.0)
LIB 142	52.00	49.250	44.625 / 44.628	49.00	5.63 (143.0)	1.00 (25.40)	9.75 (247.7)
LIB 242	(1,320.8)	(1,250.95)	(1,133.48 / 1,133.55)	(1,244.6)	7.50 (190.5)		13.5 (342.9)
LIB 148	61.00	58.000	52.000 / 52.005	56.75	6.00 (152.4)	0.00 (0.0)	10.69 (271.5)
LIB 248	(1,549.4)	(1,473.20)	(1,320.80 / 1,320.93)	(1,441.5)	8.75 (222.3)	1.00 (25.4)	15.06 (382.5)
LIB 260	70.50	74.500	60.000 / 59.990	70.50	9.38 (238.3)	3.50 (88.9)	21.25 (539.8)
LIB 360	(1,790.7)	(1,892.30)	(1,524.0 / 1,523.7)	(1,790.7)	12.25 (311.2)		22.88 (581.2)

Dimensions: inches (mm)

Model Size ATD-	J	L		M	N	Q	R		T	U	
		No.-	Size				No. -	Size		Min.	Max.
LIB 106	0.06	4 -	0.34 (8.6)	4.19	2.69 (68.3)	0.56	2 -	1/4 NPT	2.00	0.60	2.00
LIB 206	(1.5)			(106.4)		(14.2)			(50.8)	(15.2)	(50.8)
LIB 142	0.25	24 -	1.06 (26.9)	29.50	18.00 (457.2)	1.50	4 -	1/2 NPT	23.88	8.00	14.00
LIB 242	(6.4)			(749.3)		(38.1)			(606.6)	(203.2)	(355.6)
LIB 148	0.25	24 -	1.06 (26.9)	32.00	25.75 (654.1)	1.50	4 -	1/2 NPT	25.25	10.00	18.00
LIB 248	(6.4)			(812.8)		(38.1)			(641.4)	(254.0)	(457.2)
LIB 260	0.38	24 -	2.06 (52.3)	35.50	27.00 (685.8)	3.25	6 -	1/2 NPT	28.5	11.00	19.00
LIB 360	(9.5)			(901.7)	28.15 (715.0)	(797.6)			(723.9)	(279.4)	(482.6)

Note: For mounting, use socket head capscrews conforming to the ASTM-574-97a.
(Consult factory for drawing before final layout.)

Air Tube Disc Clutches and Brakes

Brake Air Hose Kits

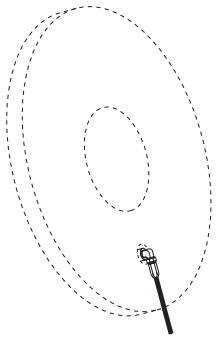

Model	Part Number
8"	8-908-912-100-5 8-908-924-100-5 QRV

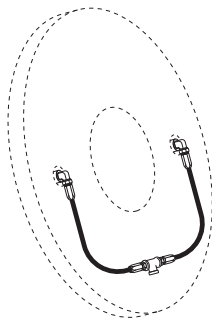

Model	Part Number
6"	8-906-912-200-4 8-906-931-201-5 QRV
8"	8-908-913-200-5 8-908-931-200-5 QRV
11"	8-911-913-200-5 8-911-931-200-5 QRV
14"	8-914-913-200-5 8-914-921-200-5 QRV
16"	8-916-913-200-5 8-916-921-200-5 QRV

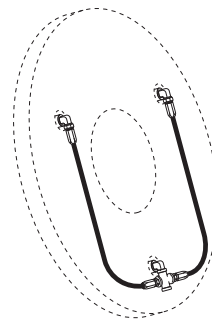

Model	Part Number
18"	8-918-912-200-5 8-918-931-200-5 QRV
21"	8-921-913-200-5 8-921-931-200-5 QRV
24"	8-924-913-200-5 8-924-931-200-5 QRV
27"	8-927-913-200-5 8-927-921-200-5 QRV

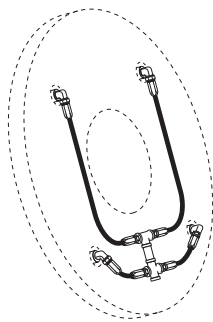

Model	Part Number
30"	8-930-913-400-5 8-930-931-400-5 QRV
36"	8-936-913-400-6 8-936-931-400-6 QRV
42"	8-942-913-400-6 8-924-931-400-6 QRV
48"	8-948-912-400-6 8-948-923-400-6 QRV

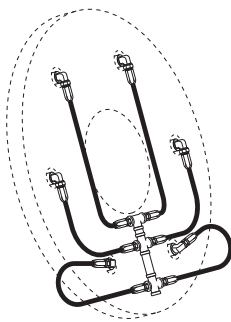

Model	Part Number
60"	8-960-912-500-5 8-960-923-400-6 QRV

Air hose kits contain all necessary parts (fittings, hoses and extensions) to completely plumb the brake air system.

Optional Quick Release Valves can replace elbows on most units (see page 35).

Roto-couplings (see page 35).

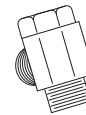

Air Tube Disc Clutches and Brakes

Low Inertia Clutches and Brakes

Component Parts

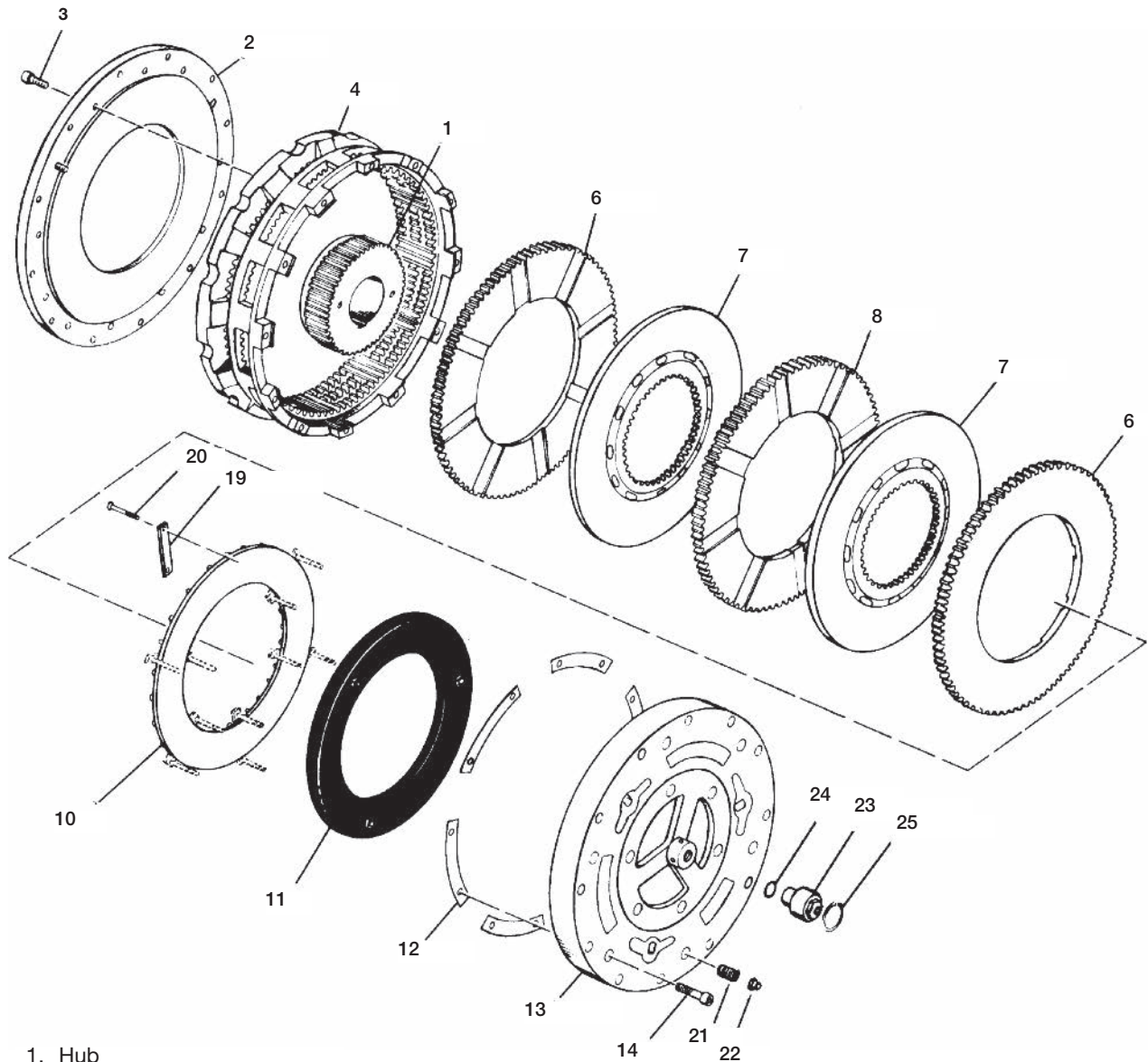

- | | | |
|---|---------------------------|---------------------|
| 1. Hub | 10. Pressure Plate | 21. Release Springs |
| 2. Demountable Back Plate | 11. Airtube | 22. Flexloc Nuts |
| 3. Socket Head Capscrews | 12. Shims | 23. Roto-coupling |
| 4. Ring | 13. Airtube Holding Plate | 24. "O" Ring |
| 6. Grooved Friction Disc
(grooved on one side) | 14. Socket Head Capscrews | 25. Snap Ring |
| 7. Center Plate | 19. Pressure Plate Lugs | |
| 8. Grooved Friction Disc
(grooved on both sides) | 20. Hex Head Capscrews | |

