

ECB TOTALLY ENCLOSED CLUTCH AND CLUTCH/BRAKE

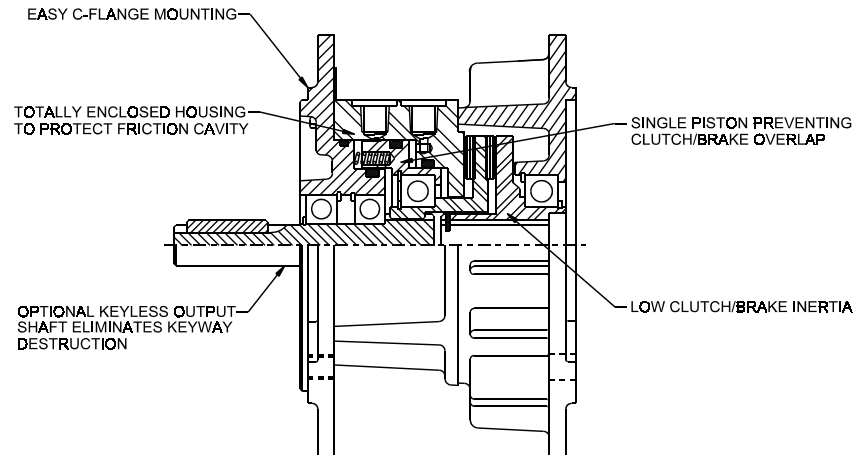

ECB PNEUMATIC CLUTCH & BRAKE COMBINATION

- **Totally enclosed housing**
 - **Protection against outside contaminants**
 - **Used in washdown applications**
 - **C-Flange Mounted**
 - **Single piston prevents clutch/brake overlap**
 - **Low inertia clutch/brake rotor**
 - **Fast cycle times**
 - **Accurate starting/stopping**
 - **Hardened steel spline connections**
 - **High temperature sealing materials**
 - **Patented keyless output shaft**
 - **Elimination of keyway destruction**
- **Bearing mounted Input shaft assembly and foot mount available**



ECB CLUTCH/BRAKE

**OPTIONAL KEYLESS
TAPER EXPANDED
OUTPUT SHAFT**

MODELS
TCC AND XLT

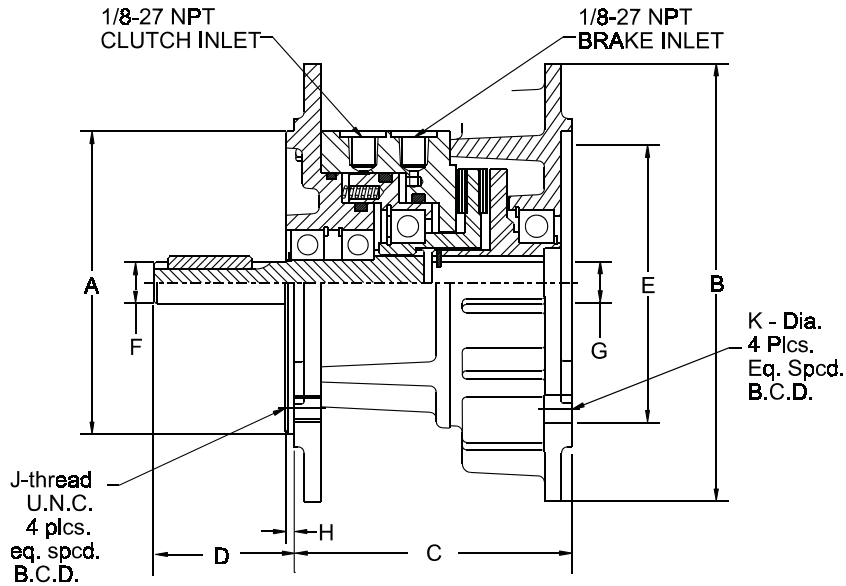

MODEL	A	B	C	D	E	F	G	H	J	K	BCD	MAXIMUM RPM ALL UNITS 1800
ECB 625-XL ECB 625-XLT	4.499	6.5	3.875	2.063	4.501	.624 .625	.626 .627	.120	.375-16	.406	5.875	
ECB 875-XL ECB 875-XLT	4.499	6.5	4.25	2.125	5.501	.874 .875	.876 .877	.120	.375-16	.406	5.875	
ECB1125-CC ECB1125-TCC	8.498	9	6	2.875	8.502	1.124 1.125	1.126 1.127	.25	.5-13	.531	7.250	

MODEL	TORQUE	STATIC	DYNAMIC	HEAT DISSIPATION	OUTPUT* SHAFT	HEAT CAPACITY	WK ² OF CYCLING PART	KEY	WEIGHT	FRAME SIZE
ECB 625-XL ECB 625-XLT	CLUTCH @ 80PSI BRAKE @ 80PSI	160 IN-LB	144 IN-LB	.12 HP	75#	12000 FT-LB	.70 IN ² LB	.188	15#	56C
ECB 875-XL ECB 875-XLT	CLUTCH @ 80PSI BRAKE @ 80PSI	270 IN-LB	243 IN-LB	.15 HP	140#	18000 FT-LB	1.90 IN ² LB	.188	20#	143TC/145TC
ECB 1125-CC ECB 1125-TCC	CLUTCH @ 80PSI BRAKE @ 80PSI	450 IN-LB	400 IN-LB	.3 HP	275#	25000 FT-LB	7.90 IN ² LB	.25	49#	182TC/184TC

*Based on 10,000 hours bearing life with load 1" from bearing face

The initial torque on new units may be up to 40% less than torque values shown in the above chart until the friction lining is worn in.

ECB REPAIR KITS			
MODEL	PART NUMBER	MODEL	PART NUMBER
ECB625-XL	5505K	ECB875-XLT	5509K
ECB625-XLT	5505K	ECB1125-CC	4115K
ECB875-XL	5509K	ECB1125-TCC	4115K

ECB CLUTCH/BRAKE OPTIONS

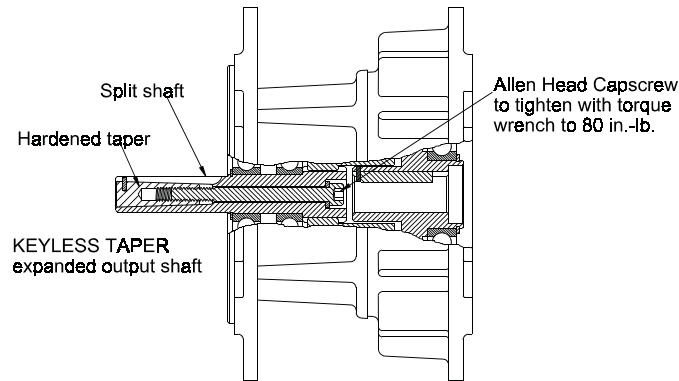

ECB-TCC and XLT allows the optimum method of transmitting torque using complete 360 degree contact between the output shaft of the clutch/brake and the reducer shaft. All clearance is eliminated resulting in a connection having over three square inches contact area.

The ECB-TCC/XLT withstands constant start-stop action and completely eliminates key or keyway destruction because of its keyless taper.

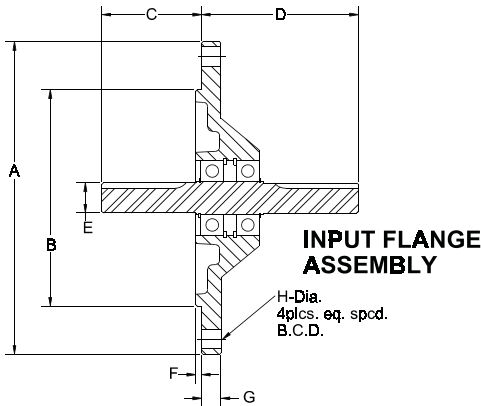

INPUT FLANGE

An optional Input Flange is available and mounts to the input of the ECB. It includes a bearing mounted, load carrying, input shaft and allows the clutch/brake to C-face to the reducer.

PART#	MODEL	A	B	C	D	E	F	G	H	BCD	WEIGHT
3971	ECB 625	6.5	4.499	2.063	3.25	.624	.120	.406	.406	5.875	5#
3982	ECB 875	6.5	4.499	2.125	3.688	.874	.120	.406	.406	5.875	6#
5004	ECB 1125	9	8.496	2.875	4.5	1.124	.250	.730	.531	7.250	16.5#

FOOT BRACKET

The foot brackets can be used with the ECB clutch/brake and adapter flange to form a foot mounted unit with bearing mounted load carrying input and output shafts.

PART#	MODEL	A	B	C	D	E	F	G	BCD
2815	625 or 875	6	4.75	3.5	2	1.5	.875	.406	5.875
4052	1125	6	6	5.25	3	2	1.25	.531	7.250

