



COMBINORM

INSTRUCTION MANUAL | Type 02 Magnetic Brake

Original manual
COMBINORM Type 02 Brake
Document 20278700 USA 00







1 Preface

The hardware and software described in this document are products of KEB America, Inc. The information contained in this document is valid at the time of publishing. KEB reserves the right to update this document in response to misprints, mistakes or technical changes.



1.1 Warning Signs and Key Symbols

Certain procedures within this document can cause safety hazards during the installation or operation of the device. Refer to the safety warnings in this document when performing these procedures. Safety signs are also located on the device where applicable. A safety warning is marked by one of the following warning signs:

	<ul style="list-style-type: none"> ➤ Dangerous situation which will cause death or serious injury if this safety warning is ignored.
	<ul style="list-style-type: none"> ➤ Hazardous situation which may cause death or serious injury if this safety warning is ignored.
	<ul style="list-style-type: none"> ➤ Hazardous situation which may cause minor or moderate injury if this safety warning is ignored.
	<ul style="list-style-type: none"> ➤ Situation which may cause property damage if this safety warning is ignored.
<i>RESTRICTION</i>	<ul style="list-style-type: none"> ➤ Used when the following statements depend on certain conditions or are only valid for certain ranges of values.
	<ul style="list-style-type: none"> ➤ Used for informational messages or recommended procedures.

1.2 More Symbols

1. Arrow icons begin action steps.
- Enumerations are marked with dots.
- Thin arrows indicate cross references to another chapter or another page.

	<p>Further documentation can be found at https://www.kebamerica.com</p> <p>Document search on www.kebamerica.com/em-documents/</p>	
---	--	---

1.3 Laws and Requirements



KEB Automation KG has certified the product against the US, Canadian and European standards. Additionally KEB Automation KG provides the EC declaration of conformity that the product complies with the essential safety requirements.

The UL, CSA and CE marks are located on the name plate when applicable. The EC declaration of conformity can be downloaded on demand via our website.

→ Further information is provided in Appendix A: Certification.

1.4 Warranty

KEB Automation KG provides a limited warranty on all products. This warranty can be found in the terms and conditions at our website.

	KEB America, Inc. Terms and Conditions Terms and Conditions	
---	--	---

Further agreements or specifications require written confirmation from KEB America, Inc.

1.5 Support and Liability

It is not possible to cover every potential application of our device in a single manual. If you require further information or if problems occur which are not covered in this document, you can request the necessary information via KEB America, Inc. or the local KEB Automation KG agency.

The use of our products in the target application is beyond our control and therefore exclusively the responsibility of the machine manufacturer, system integrator or customer.

The information contained in this document, as well as any user-specific advice in spoken or written form or generated through testing, is provided to best of our knowledge and is considered for informational purposes only. KEB America, Inc. bears no responsibility or liability for the accuracy of the information listed above, nor for any violation of industrial property rights committed by a third-party in relation to this information.

Selection of the most suitable product for any given application is the responsibility of the machine manufacturer, system integrator or customer.

Evaluation of the product can only be performed by the machine manufacturer in combination with the application. Any tests performed must be repeated every time any part of the hardware or software is modified, or any time the unit adjustment is changed.

1.6 Copyright

The customer may use the information contained within this document for internal purposes only. Copyright of this document is held by KEB America, Inc. and remains valid in its entirety.

Other wordmarks or/and logos are trademarks (™) or registered trademarks (®) of their respective owners and are listed in a footnote at the first occurrence.

Table of Contents

1	Preface	3
1.1	Warning Signs and Key Symbols	3
1.2	More Symbols	3
1.3	Laws and Requirements.....	4
1.4	Warranty	4
1.5	Support and Liability	4
1.6	Copyright.....	4
	Table of Contents.....	5
	List of Figures	7
	List of Tables.....	8
	Glossary	9
	Standards for COMBINORM Type 02 Brakes	12
2	Safety Instructions	13
2.1	Target Audience.....	13
2.2	Specified Application.....	14
2.3	General Safety Guidelines.....	14
2.4	Electrical Safety Guidelines	14
2.5	Installation and Operation Safety Guidelines	15
2.6	Maintenance Safety Guidelines	15
2.7	Personal Protective Equipment	16
2.8	Permissible Friction Work.....	16
3	Product Description	17
3.1	Scope of this Manual	17
3.2	Description	17
3.3	Brake Assembly Numbering Scheme.....	18
3.4	Brake Components	20
3.4.1	Flange-Mounted Brake without Hub	20
3.4.2	Flange Mounted Brake with Internal Hub	20
3.4.3	Flange-Mounted Brake with External Hub.....	21

3.4.4	Shaft-Mounted Brake	21
4	Transportation and Storage	22
4.1	Inspection on Delivery	22
4.2	Unloading and Moving the Device	22
4.3	Packaging.....	22
4.4	Temporary Storage	22
5	Installation	23
5.1	Before You Begin.....	23
5.2	Mounting Surface Requirements	23
5.2.1	Brake Centering.....	24
5.3	Air Gap Settings.....	24
5.4	Brake Installation	25
5.4.1	Flange-Mounted Brake without Hub	25
5.4.2	Flange-Mounted Brake with Internal Hub.....	26
5.4.3	Flange-Mounted Brake with External Hub.....	27
5.4.4	Shaft-Mounted Brake	29
5.5	Electrical Installation	30
5.6	Removing the Brake	30
6	Operation	31
6.1	Before You Begin.....	31
6.1.1	Running-In Process	31
7	Maintenance and Troubleshooting	32
7.1	Maintenance	32
7.1.1	Checking the Air Gap	32
7.1.2	Adjusting the Air Gap	33
7.1.3	Cleaning the Brake.....	33
7.2	Troubleshooting.....	34
8	Appendix.....	35
8.1	Appendix A: Certification	35
8.2	Appendix B: Technical Specifications	36
9	Revision History	38

List of Figures

Figure 1 Brake Function On	17
Figure 2 Brake Function Off	17
Figure 3 Flange Mount without Hub Parts.....	20
Figure 4 Flange Mount with Internal Hub Parts.....	20
Figure 5 Flange Mount with External Hub Parts.....	21
Figure 6 Shaft Mounted Parts	21
Figure 7 Runout and Concentricity.....	24
Figure 8 Brake Centering	24
Figure 9 Installation Components	25
Figure 10 Installed Brake	25
Figure 11 Installation Components	26
Figure 12 Installed Brake	26
Figure 13 Installation Components	27
Figure 14 Installed Brake	27
Figure 15 Securing the Hub	28
Figure 16 Installation Components	29
Figure 17 Installed Brake	29

List of Tables

Table 1 Hub and Rotor Bore Diameter.....	19
Table 2 Mounting Surface Requirements.....	23
Table 3 Air Gap Widths.....	24
Table 4 Air Gap Widths and Maximums by Brake Size.....	32
Table 5 Troubleshooting	34
Table 6 Basic Characteristics.....	36
Table 7 Brake Weight by Size.....	36
Table 8 Technical Specifications.....	37

Glossary

AC	Alternating current.
Aggressive Fumes/Liquids	Gasses or liquids that are chemically reactive and may cause corrosion in exposed machine parts.
Air Gap	The gap between the armature and the magnet. This air gap must be precisely calibrated to a specific width, denoted as X. If the air gap is too wide, the braking torque is reduced. If the air gap is too narrow, the brake may not release correctly.
Application	The machine/system in which the KEB device is to be used. For brakes the application is typically the motor to which the brake is attached.
Armature	The component of the brake which rotates with the driven shaft/surface and presses against the magnet to engage the brake.
AWG / Wire Gauge	American Wire Gauge. A measure of the thickness of a wire using standardized sizes.
Branch Circuit Protection	Circuit protection for the portion of the electrical distribution system that extends beyond the final branch circuit protection device. A branch circuit is used to run motors or other appliances, and is what is commonly found inside a building.
CE	European safety standards for products in the European Economic Area. Manufacturers self-test products against these standards to maintain CE certification. The CE mark indicates a product meets EEA safety standards.
CEC	Canadian Electric Code. Safety standard for electrical installations used in Canada.
Control Device/Interface	The COMBINORM brake is controlled electronically by a control device. This can be as simple as a switch, or as complex as a full suite of control software.
CSA	Canadian Standards Authority, also known as CSA Group. Organization that tests and certifies products according to Canadian safety standards. The CSA mark indicates a product meets Canadian safety standards.
Customer	The corporation or individual who purchased the COMBINORM brake.
DC	Direct current.
Device / KEB Device	The COMBINORM brake described in this manual.
Drive Shaft	A mechanical component for transmitting torque and rotation from a motor to other parts of a mechanical system.

Driven Shaft/Surface	A rotating component of a mechanical system which is driven by a drive shaft. Typically connected to the drive shaft via a clutch to allow the driven shaft/surface to be engaged when needed. The driven shaft/surface refers to the component directly connected to the drive shaft. See Load for a broader term for all parts of the system driven by the motor.
Dry running	Operation in dry environments with no danger of dripping or splashing liquids.
EC Declaration of Conformity	Declaration that the device conforms to EU standards of safety.
Equipotential Bonding	A practice of intentionally electrically connecting all exposed metal items not designed to carry electricity in a room as protection from electric shock.
Flange	A plate integrated on the magnet housing used to mount the brake magnet.
Friction Surface	The surface of the armature and magnet that contact during brake engagement.
KEB Automation KG	Parent company of KEB America, Inc. Also referred to as KEB.
Load	The components of a mechanical system driven by a motor. The load refers to the entire system powered by the motor. See Driven Shaft/Surface for the individual component connected directly to the drive shaft.
Machine Manufacturer	The manufacturer of the application in which the COMBINORM brake is installed. Not KEB America, Inc.
Magnet	The component of the brake which contains the magnetic components.
Mounting Surface	A surface to which the COMBINORM device is physically attached. The COMBINORM is typically attached to the mounting surface with the recommended socket-head screws, but other fastening methods may be used as appropriate to the application.
NEC	US National Electric Code. Safety standard for electrical installations used in the United States.
Product / KEB Product	See Device.
Recommended tightening torque	The torque required to fully screw a socket head screw into a mounting surface. The recommended tightening torque depends on the type of screw used as well as the material, thread depth and locking components (if any) used in the mounting surface. Refer to the machine manufacturer for details on recommended tightening torques for specific mounting surfaces.
Run-out	An inaccuracy of rotating mechanical systems whereby the shaft does not rotate precisely in line with the main axis. Always present but must be minimized.
Specified Application	The specific application for which the COMBINORM device was ordered, is usually (but not always) the same as the Application in which the device is being used.

System Integrator

The technician installing the COMBINROM brake into the application.

UL

Independent Standardization Company that tests and certifies products according to defined and industry leading safety standards. The UL mark indicates a product meets UL safety standards.

Standards for COMBINORM Type 02 Brakes

The COMBINORM installation must comply with all relevant safety standards. The following standards are relevant to the installation and operation of the COMBINORM type 02 Brake.

- **Directive 2006/42/EC (annex I)**
 - Region: EU
 - Essential health and safety requirements for the design and construction of machinery.
- **C22.1-18: Canadian Electric Code, Part 1 (CEC)**
 - Region: Canada
 - Electric safety code detailing safety standards for electric installations in Canada.
- **NFPA 70: National Electric Code (NEC)**
 - Region: US
 - Electric safety code detailing safety standards for electric installations in the United States.
- **NFPA 79: Electrical Standard for Industrial Machinery**
 - Region: US
 - Industrial safety code detailing safety standards for industrial machinery to protect against fire and electrical hazards.
- **OSHA 1910.137**
 - Region: US
 - Personal safety code detailing appropriate personal protective equipment for working on electrical installations.
- **OSHA 1910.269**
 - Region: US
 - Occupational safety code detailing safety standards for electrical power generation, transmission, and distribution.

2 Safety Instructions

The COMBINORM is designed and constructed with state-of-the-art technology in accordance with recognized safety rules and regulations. Improper use of this device may cause hazards to life and limb of the user or third-parties, or damage to the application and other material property.

The following safety instructions have been created by KEB America, Inc. for the COMBINORM type 02 brake. These instructions can be supplemented by local, country- or application-specific safety instructions where relevant.

Violation of the safety instructions in this manual will result in the loss of any liability claims.

NOTICE

Stay Safe! Stay Informed!

- Read the instruction manual prior to operating the device!
 - Follow all safety and warning instructions!
 - If you are unsure of any part of these instructions, please contact KEB prior to operating the device!
-

2.1 Target Audience

This manual is intended exclusively for the use of qualified electrical/mechanical technicians. Qualified technicians for the purpose of this document must meet the following:

- Must have fully read and understood the safety instructions contained in this manual.
- Must be familiar with the installation and assembly of electrical products.
- Must be familiar with the installation and operation of the product as specified in this manual.
 - See the Installation and Operation chapters for details.
- Must fully understand the specified application of the product.
 - See the Specified Application section for details.
- Must be familiar with the hazards and risks of electrical brake technology.
- Must be familiar with appropriate electrical and safety codes:
 - **US:** NFPA 70 National Electric Code (NEC)
 - **Canada:** Canadian Electric Code, C22 Part 1 (CEC)
- Must be familiar with national safety regulations (e.g. OSHA Title 29 CFR):
 - See the Standards for COMBINORM Type 02 Brakes section for details.

2.2 Specified Application

The operational reliability of the COMBINORM is only guaranteed when the device is used for the specified application. In this context, specified application means the purpose for which the COMBINORM was ordered and configured.

Any use of the COMBINORM outside of this specified application is considered at the user's own risk. Such unintended uses may pose unforeseeable risks or hazards. KEB America, Inc. retains no liability for any damage or injury resulting from the use of a COMBINORM outside of the specified application.

2.3 General Safety Guidelines

Carefully observe the following safety guidelines before installation or operation of the device.

- Only trained personnel should operate the brake.
- Immediately remove the brake from operation in case of a malfunction.
- Malfunctions should be corrected by trained personnel before returning the brake to operation.
- Never use the brake in potentially explosive environments.
- The brake may not be modified or altered in any way not intended by KEB America, Inc.

2.4 Electrical Safety Guidelines

 **DANGER**

Risk of electrical shock!

- Turn off the power supply and secure it against switching on prior to any work on the device.
 - Wait until the system has come to a complete stop prior to any work on the device.
 - Never bridge branch circuit protection devices.
-

- Observe all relevant safety standards during the electrical installation.
 - See the Standards for COMBINORM Type 02 Brakes section for details specific to the product.
- Use only wire gauges and fuses rated for the power requirements of the device.
- Ensure new or existing circuits meet NEC or applicable local requirements.
- The device must be appropriately grounded by a connector from the magnet and the fixed installation.
- When using components without isolated inputs/outputs, equipotential bonding must be used between the connected components to prevent damage to the device.
- Do not exceed specified electrical voltage and current limits.
 - See Appendix B: Technical Specifications for details.

2.5 Installation and Operation Safety Guidelines

⚠ WARNING

Moving parts can crush and cut!

- Contact with rotating or moving parts may cause serious injury. Ensure adequate protection around the brake to prevent accidental contact!

⚠ CAUTION

Hot Surfaces!

- The heat generated during the operation of the brake may cause burns on contact with skin. Always wear appropriate protective equipment!

Do not start the device until you have confirmed that the installation complies with the following safety standards.

- Ensure there is sufficient protection against foreign particles entering the air gap. These particles may impede the motion of the armature.
- Ensure there is sufficient thermal protection such that the brake does not exceed or fall below the listed temperature limits for the device.
 - See Appendix B: Technical Specifications for details.
- Ensure there is protection against accidental contact with rotating or moving parts.
- Ensure there is sufficient protection from environmental factors such as moisture or aggressive gases that may compromise the integrity of the friction surface or armature.

2.6 Maintenance Safety Guidelines

⚠ DANGER

Risk of electrical shock!

- Turn off the power supply and secure it against switching on prior to any maintenance on the brake.

⚠ WARNING

Moving parts can crush and cut!

- Contact with rotation or moving parts may cause serious injury. Wait until the drive has come to a complete stop before performing any maintenance.
- Secure the drive against accidental movement prior to performing any maintenance.

⚠ CAUTION

Hot Surfaces!

- The heat generated during the operation of the brake may cause burns on contact with skin. Always wear appropriate protective equipment.

Carefully observe the following safety guidelines before performing maintenance on the brake.

- Ensure the device is powered off and has come to a complete stop before performing any maintenance.
- Secure the brake so it cannot be switched on accidentally during maintenance.
- Disconnect the brake from the load before maintenance to avoid uncontrolled movements.
- Ensure there is sufficient protection against foreign particles entering the air gap during maintenance.
- Ensure there is sufficient protection against moisture or aggressive gasses that may compromise the integrity of the friction surface or armature.
- Ensure the friction lining does not come into contact with cleaning agents or solvents.

2.7 Personal Protective Equipment

When installing or performing maintenance on the brake, use the following personal protective equipment:

- Long-sleeved protective clothing
- Safety gloves
- Safety shoes
- Safety goggles

The personal protective equipment must be provided by the operating company and must comply with any applicable safety regulations.

→ See Standards for COMBINORM Type 02 Brakes for details.

2.8 Permissible Friction Work

When operating the brake adhere to the friction work values specified in Appendix B: Technical Specifications, taking the speed and frequency of operation into account. Exceeding these values may result in thermal overload of the friction lining and a strong decrease in braking torque.

3 Product Description

3.1 Scope of this Manual

This manual describes the installation and function of the COMBINORM Type 02 Brake, as well as standard maintenance and troubleshooting procedures.

This manual covers the following brake models:

- COMBINORM Type 02 Flange-Mounted Brake
- COMBINORM Type 02 Shaft-Mounted Brake

3.2 Description

The COMBINORM Type 02 is a single face electromagnetic brake designed for dry operation. The brake consists of a magnet assembly and an armature with built in flat spring. The magnet and armature are installed with an air gap of width X between the components. The magnet assembly is mounted on a solid surface or directly to the motor while the armature is mounted to the rotating components; either directly to the shaft for brakes with hubs or a rotating mounting surface.

When powered on the magnet attracts the armature plate to the friction surface integrated into the magnet assembly providing backlash free braking torque.

When powered off the flat spring pulls the armature plate away from the friction surface, releasing the brake and allowing free rotation of the armature and mounting surface.

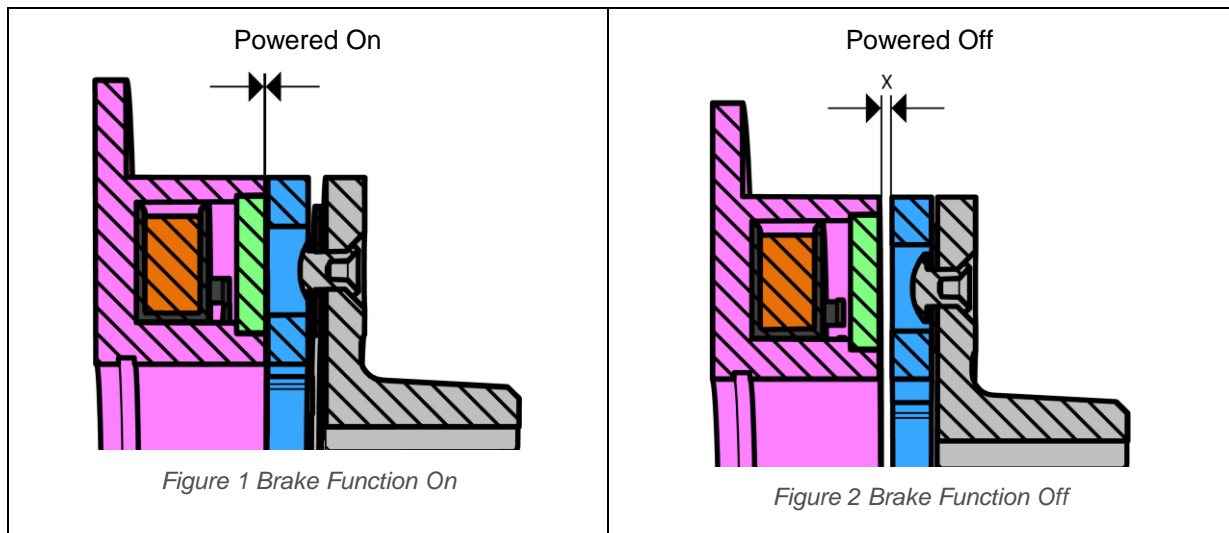

3.3 Brake Assembly Numbering Scheme

The part number for COMBINORM brakes takes the following format. The part number can be found on the name plate of the device.

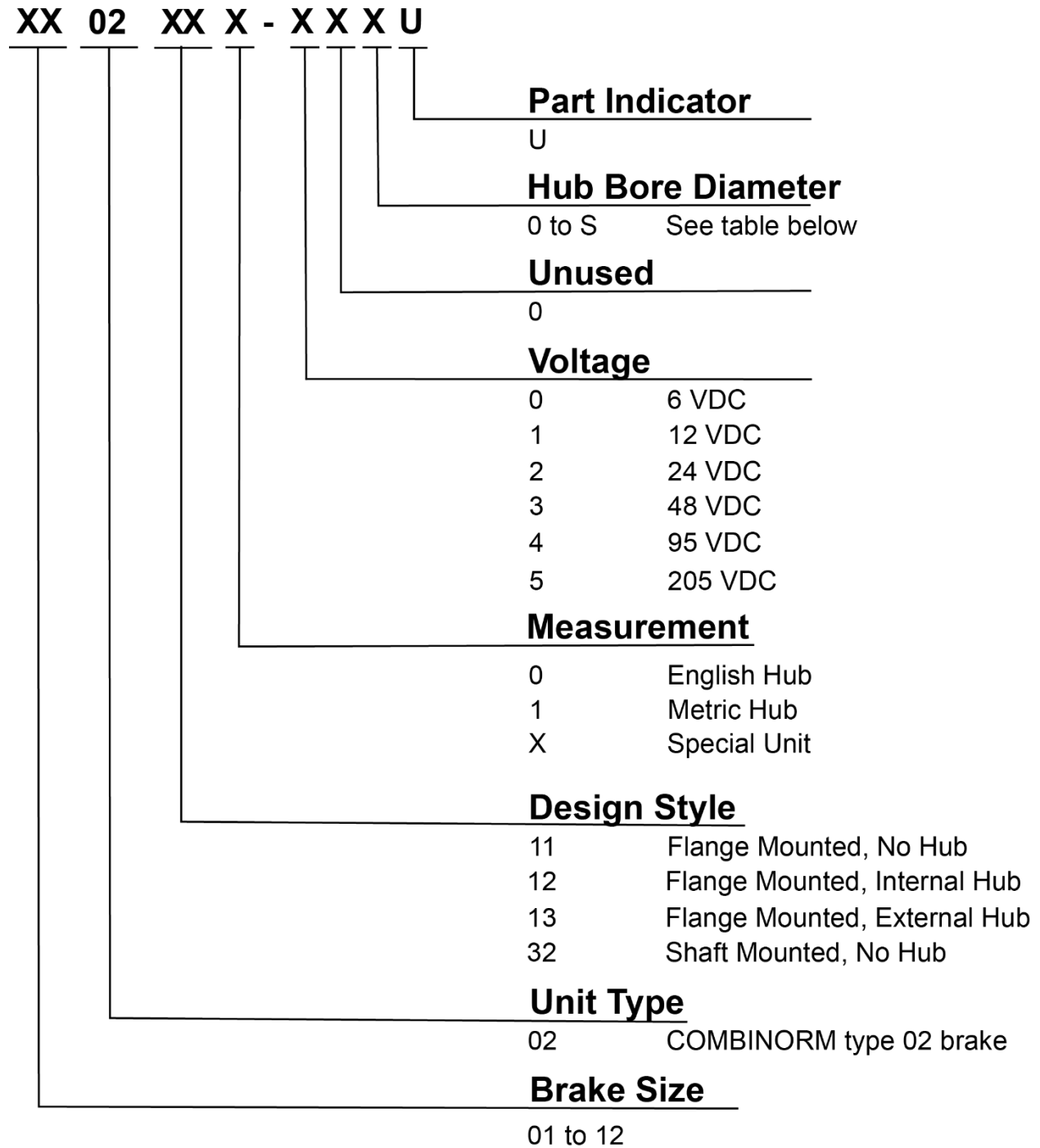

Hub and Rotor Bore Diameter		
Number	English	Metric
0	None	None
1	1/4"	3mm
2	5/16"	5mm
3	3/8"	6mm
4	1/2"	7mm
5	5/8"	8mm
6	3/4"	9mm
7	7/8"	10mm
8	1.0"	11mm
9	1 1/8"	12mm
A	1 1/4"	13mm
B	1 3/8"	14mm
C	1 1/2"	15mm
D	1 5/8"	16mm
E	1 3/4"	17mm
F	1 7/8"	18mm
G	2.0"	19mm
H	2 1/8"	20mm
I	2 1/4"	22mm
J	2 3/8"	24mm
K	2 1/2"	25mm
L	2 5/8"	28mm
M	2 3/4"	30mm
N	2 7/8"	32mm
P	3.0"	35mm
Q	3 1/4"	38mm
R	-	40mm
S	-	42mm

Table 1 Hub and Rotor Bore Diameter

3.4 Brake Components

3.4.1 Flange-Mounted Brake without Hub

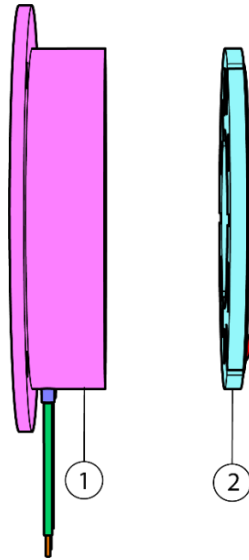

Number	Description
1	Magnet
2	Armature

Figure 3 Flange Mount without Hub Parts

3.4.2 Flange Mounted Brake with Internal Hub

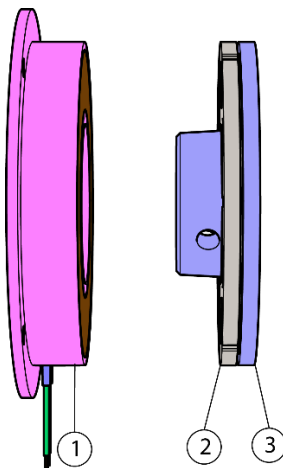

Number	Description
1	Magnet
2	Armature
3	Internal Hub

Figure 4 Flange Mount with Internal Hub Parts

3.4.3 Flange-Mounted Brake with External Hub

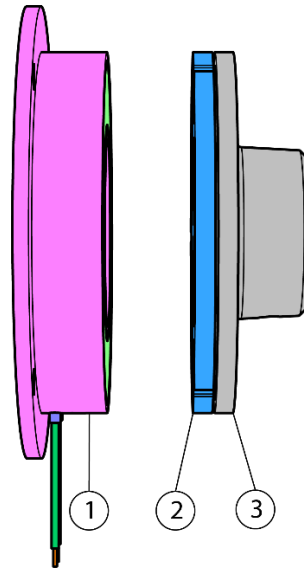

Number	Description
1	Magnet
2	Armature
3	External Hub

Figure 5 Flange Mount with External Hub Parts

3.4.4 Shaft-Mounted Brake

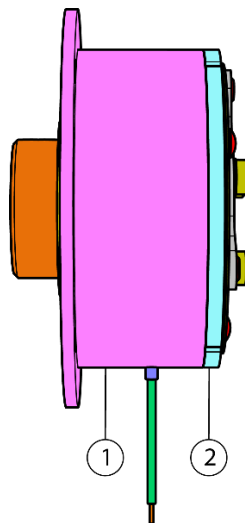

Number	Description
1	Magnet
2	Armature

Figure 6 Shaft Mounted Parts

4 Transportation and Storage

The COMBINORM brake is shipped to the customer by an authorized freight company.

4.1 Inspection on Delivery

The COMBINORM brake should be fully inspected on delivery.



-
- Report any shipping damage to the device or packing to the shipping company and to KEB America, Inc.
-

4.2 Unloading and Moving the Device

Large sizes of the COMBINORM brake can be too heavy to safely move by hand. Use appropriate lifting devices to move and transport large size COMBINORM brakes.

→ See Appendix B: Technical Specifications for size and weight details.

4.3 Packaging

COMBINORM brakes are typically shipped using biodegradable cardboard packaging or wooden crates. Packaging should be recycled or disposed of according to local regulations.

4.4 Temporary Storage

If the COMBINORM brake is not installed immediately upon delivery it must be stored in a dry, environmentally appropriate location.

Excessive dust, moisture, or aggressive liquids or gasses can result in corrosion of the brake and can impair the function of the device when it is installed.



-
- KEB America, Inc. is not liable for any damage that results from improper storage of the COMBINORM brake.
-

5 Installation



The COMBINORM type 02 brake is designed to be mounted directly over the drive shaft and affixed to a solid mounting surface. The mounting surface can be the motor itself or it can be another solid structure.

5.1 Before You Begin

Fill out the following pre-install checklist before you begin installing the COMBINORM brake.

- Fully read and understand all installation safety guidelines.**
→ See section Installation and Operation Safety Guidelines for details.
- Ensure the power supply meets the output requirements of the specific brake being installed.
→ See Appendix B: Technical Specifications for details.
- Ensure the brake is not damaged or corroded, and that no foreign material obstructs the air gap of the device. If corrosion is present thoroughly clean off any corrosion with appropriate cleaning materials.
- Ensure the friction surfaces are free of grease or oil. Clean all friction surfaces thoroughly before installing the brake. Use only sealed bearings when installing the brake.
 - Never use aggressive fluids to clean the friction surfaces. KEB America recommends using an alcohol based industrial brake cleaner.
- Ensure the installation location is protected from humidity or aggressive gasses/liquids which may degrade the friction surface.
- Ensure the installation location has adequate thermal protection to prevent the brake from freezing. Freezing of the armature will result in a loss of braking torque.
- Ensure the installation location is shielded against metal chips and other magnetic particles which may be attracted to the magnet and cause loss of braking torque.
- Ensure the mounting bolt circle and surface meet the installation requirements for eccentricity and angular deviation.
→ See section Mounting Surface Requirements for details.

5.2 Mounting Surface Requirements

The magnet and armature element must be precisely centered over the drive shaft before mounting. The runout from the shaft to the mounting frame (A to ) and the concentricity from the shaft to the edge of the magnet (A to ) must be equal or lower to the values specified below or the brake may fail prematurely due to excessive wear and tear.



Size	01	02	03	05	06	07	08	09	10	11	12
 Runout (mm)	0.03	0.03	0.03	0.05	0.05	0.05	0.07	0.1	0.15	0.15	0.15
 Concentricity (mm)	0.1	0.1	0.15	0.15	0.2	0.2	0.2	0.2	0.3	0.3	0.3

Table 2 Mounting Surface Requirements

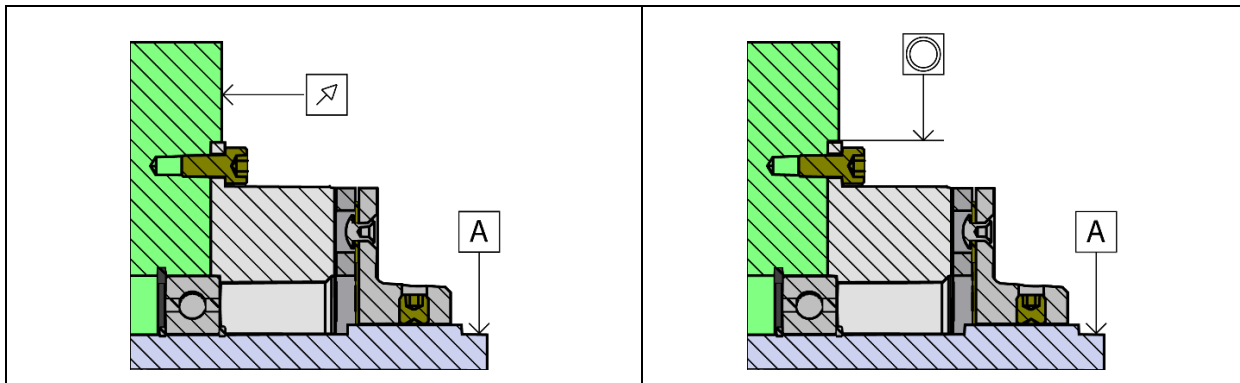

Figure 7 Runout and Concentricity

5.2.1 Brake Centering

The brake can be centered on the mounting surface to an external frame via the outer diameter of the magnet (OD centering) or to a bearing centered on the shaft via the inner diameter of the magnet (ID centering). The magnet includes a retaining ring groove for ID centering. See the KEB Catalog for dimensions for bearings and frames.

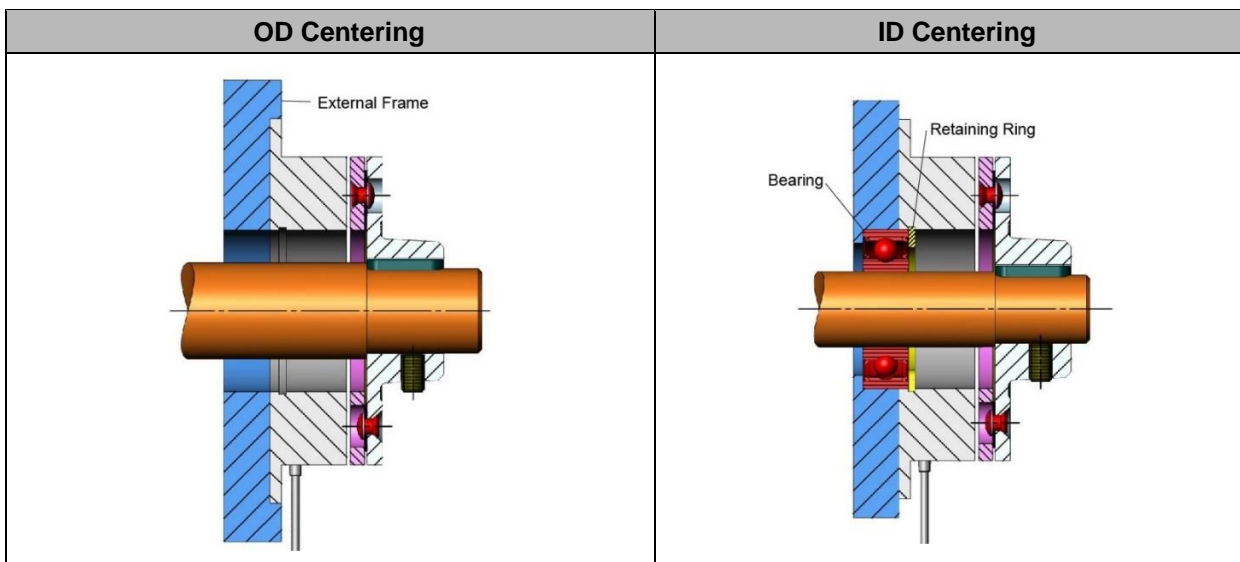

Figure 8 Brake Centering

5.3 Air Gap Settings

All COMBINORM brakes feature an air gap between the magnet and armature. This is required for proper functioning of the brake. Shaft-mounted brakes include a pre-configured air gap but flange-mounted brakes require the air gap to be set during installation. The correct air gap width X for each size of brake is listed below. Reference this table when installing any flange-mounted COMBINORM brake.

Brake Size	01	02	03	05	06	07	08	09	10	11	12
Air Gap X [mm]	0.1	0.15	0.15	0.2	0.2	0.2	0.2	0.3	0.3	0.4	0.4

Table 3 Air Gap Widths

5.4 Brake Installation

5.4.1 Flange-Mounted Brake without Hub

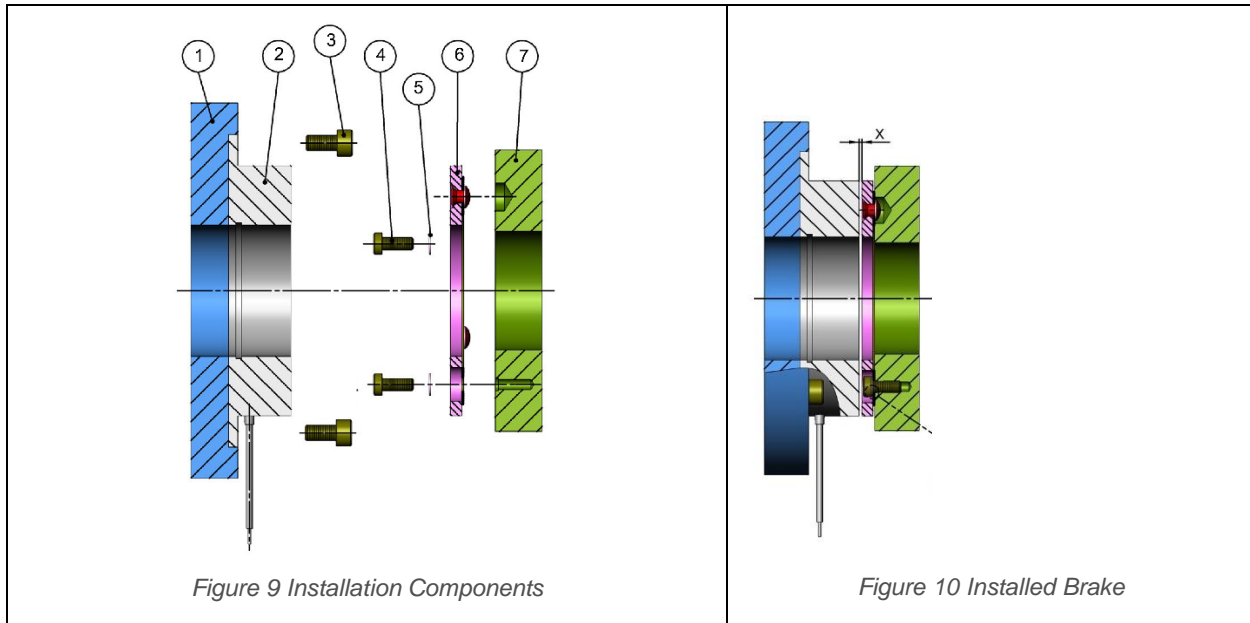

Figure 9 Installation Components

Figure 10 Installed Brake

Number	Description
1	Magnet-Side Mounting Surface
2	Magnet
3	Socket-Head Screws (ISO 4762)
4	Socket-Head Screws (ISO 6912)
5	Schnorr-Lock Washers
6	Armature
7	Load-Side Mounting Surface (customer provided)

1. Align the magnet (2) to the mounting surface (1) such that the magnet is centered over the shaft.
→ See Brake Centering for details.
2. Fix the magnet (2) to the mounting surface (1) with socket-head screws (3).
3. Align the armature (6) to the mounting surface (7) such that the armature is centered over the shaft.
4. Fix the armature (6) to the mounting surface (7) with socket-head screws (4) and Schnorr-lock washers (5). Bolt heads must remain below armature surface.
5. Mount the load-side mounting surface (7) over the shaft and adjust until the gap between magnet and armature reaches the correct width (denoted X).
→ See section Adjusting the Air Gap for details on the correct air gap by brake size.
6. Fasten the load-side mounting surface axially ensuring that the air gap remains the proper width.

5.4.2 Flange-Mounted Brake with Internal Hub

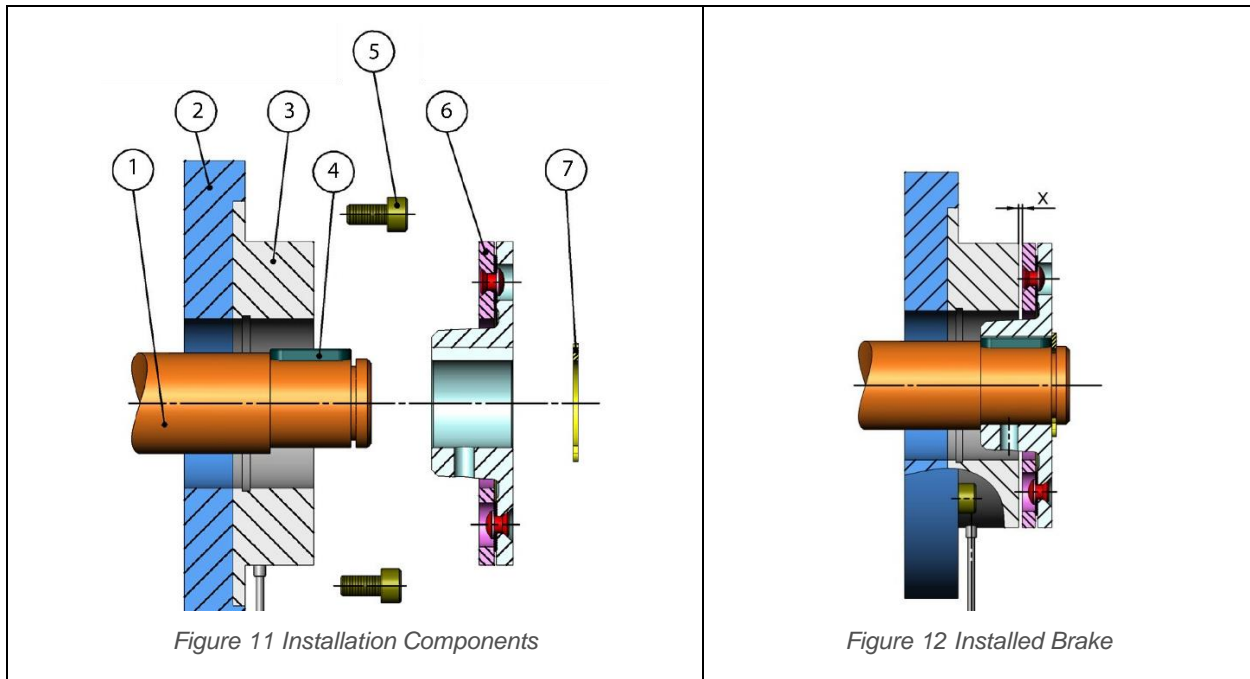

Number	Description
1	Shaft
2	Mounting Surface
3	Magnet
4	Key
5	Socket-Head Screws (ISO 4762)
6	Armature with Internal Hub
7	Retaining Ring

1. Align the magnet (3) to the mounting surface (2) such that the magnet is centered over the shaft.
→ See Brake Centering for details.
2. Fix the magnet (3) to the mounting surface (2) with socket-head screws (5).
3. Mount the armature/hub assembly (6) over the shaft (1) and slide toward the magnet until the armature and magnet are separated by an air gap of width X (shim washers can be used between hub and shaft shoulder).
→ See Adjusting the Air Gap for details.
4. Secure the armature assembly (6) in place using retaining rings (7), keys (4), or other methods to fit the specific application.
5. Check the air gap to ensure it falls within the correct parameters. If the air gap is not at width X, repeat steps 3 and 4 until the air gap is at the correct width.

5.4.3 Flange-Mounted Brake with External Hub

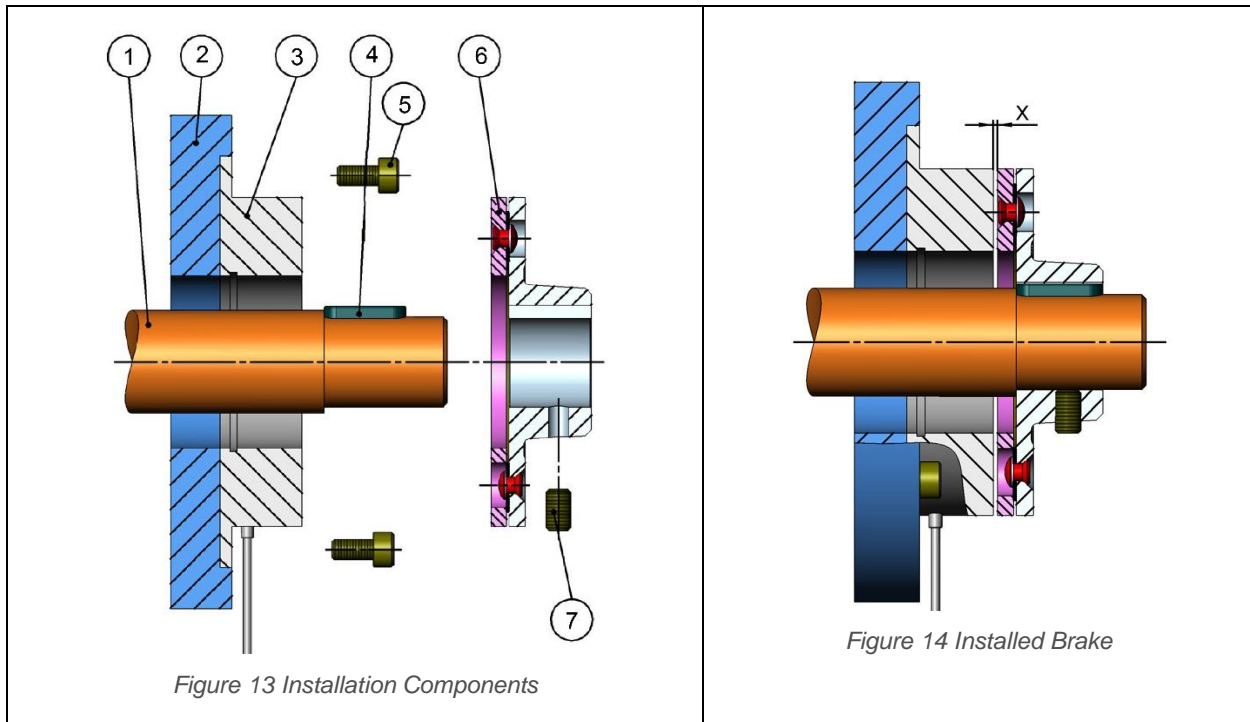

Figure 13 Installation Components

Figure 14 Installed Brake

Number	Description
1	Shaft
2	Mounting Surface
3	Magnet
4	Key
5	Socket-Head Screws (ISO 4762)
6	Armature with External Hub
7	Set Screw

1. Align the magnet (3) to the mounting surface (2) such that the magnet is centered over the shaft.
→ See Brake Centering for details.
2. Fix the magnet (3) to the mounting surface (2) with socket-head screws (5).
3. Mount the armature/hub assembly (6) over the shaft (1) and slide toward the magnet until the armature and magnet are separated by an air gap of width X (shim washers can be used between hub and shaft shoulder).
→ See Adjusting the Air Gap for details.
4. Secure the armature assembly (6) in place using a set screw or shaft bolt and washer end plate as shown on the next page.

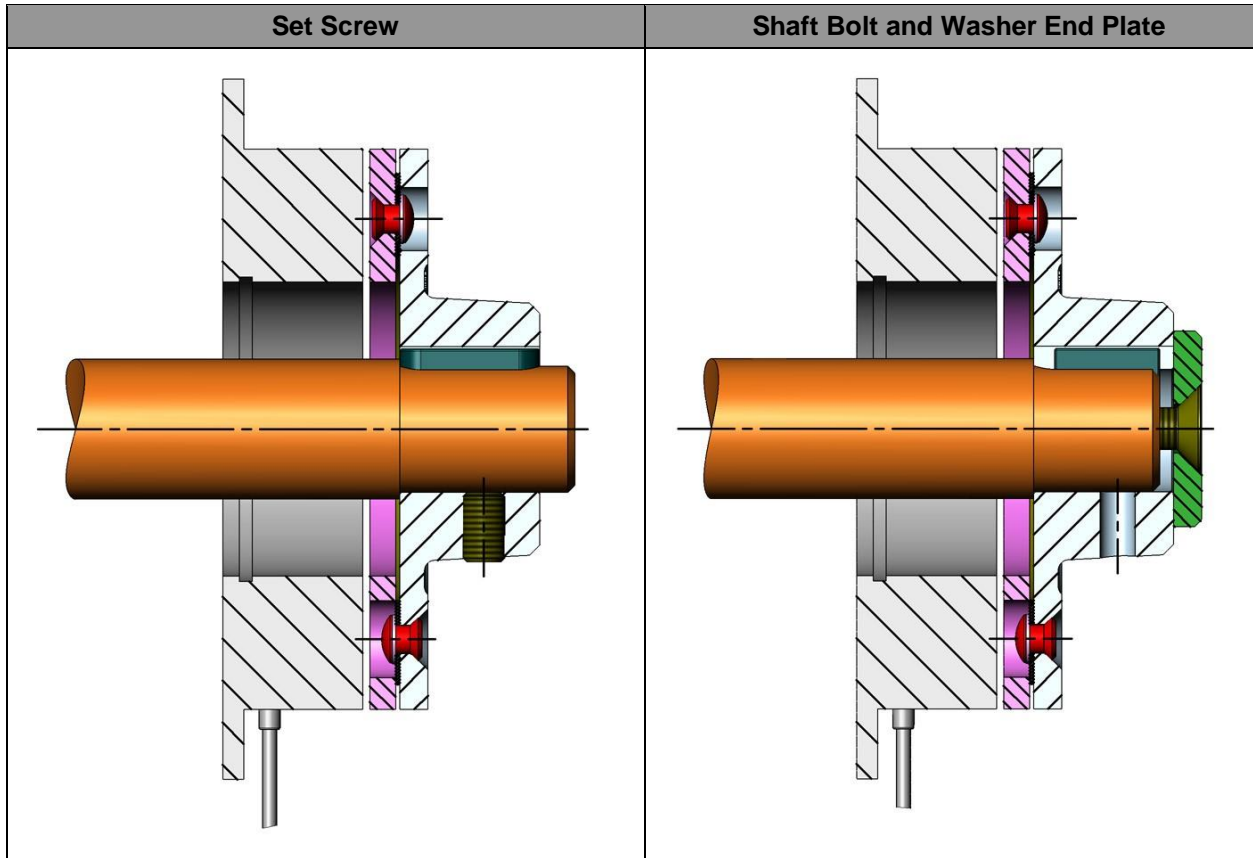

Figure 15 Securing the Hub

5. Check the air gap to ensure it falls within the correct parameters. If the air gap is not at width X, repeat steps 3 and 4 until the air gap is at the correct width.

5.4.4 Shaft-Mounted Brake

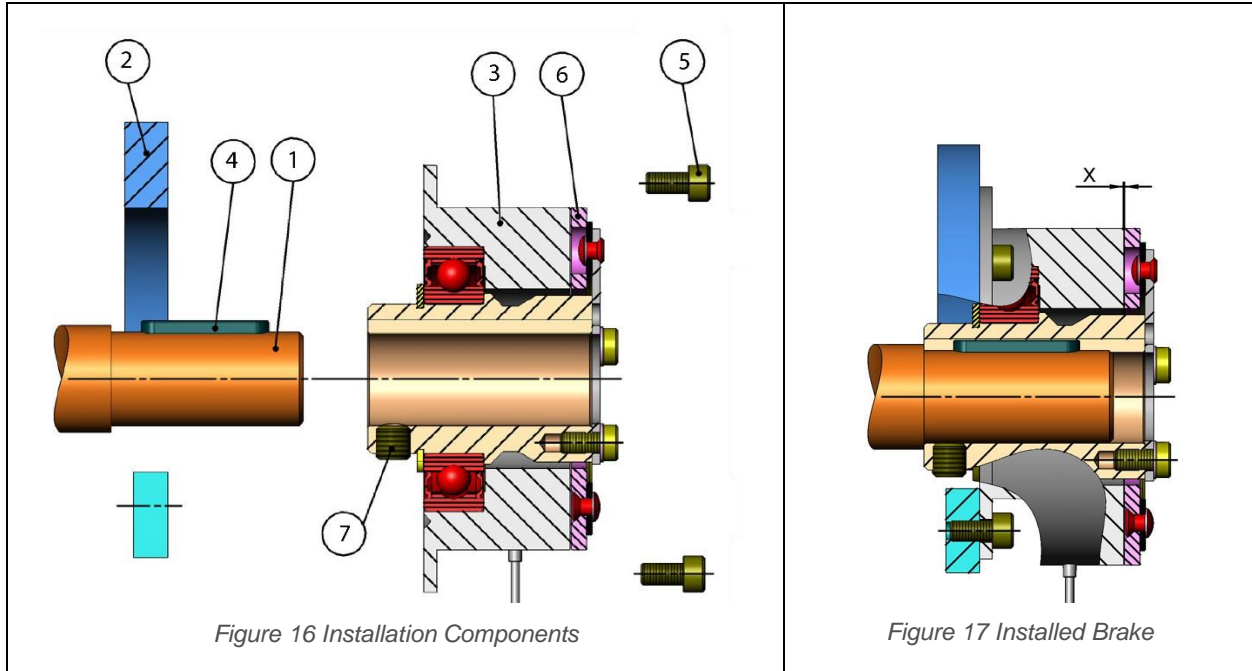

Figure 16 Installation Components

Figure 17 Installed Brake

Number	Description
1	Shaft
2	Mounting Surface
3	Brake Assembly
4	Key
5	Socket-Head Screws (ISO 4762)
6	Built-In Armature Element
7	Set Screw

1. Install the key (4) onto the shaft (1).
2. Slide the brake assembly (3) onto the shaft (1) and key (4).
3. Fix the brake assembly (3) to the mounting surface (2) with socket-head screws (5).
4. Secure set screw.



➤ The shaft-mounted brake comes pre-configured with an appropriate air gap between armature and magnet. The air gap does not need to be adjusted during installation.

5.5 Electrical Installation

The COMBINORM type 02 brake is delivered with factory-preassembled connecting cables.



Risk of electrical shock!



- Before each start-up of the system, check electrical equipment for visible defects such as loose connections or damaged insulation.
- Have an electrician remedy any defects before powering on the brake.



Risk of Damage to Brake!

- Before connecting the electrical equipment check the available supply voltage and verify it is within the nominal DC voltage for the brake.
- Powering the brake outside of the nominal DC voltage will damage the brake.

The COMBINORM brake must be powered by a nominal DC voltage. If such a voltage is not available, an AC to DC rectifier is available for purchase from KEB America, Inc.

	<p>Further information can be found in the COMBITRON Rectifier manual available at www.kebamerica.com.</p> <p>Rectifier Manual at www.kebamerica.com</p>	
--	--	--

The nominal DC voltage can be found on the name plate of the device as well as in Appendix B: Technical Specifications.

5.6 Removing the Brake

The COMBINORM brake is designed to be simple to remove. To remove any model of brake, following the installation instructions in reverse order; omitting the steps which involve setting the air gap.

6 Operation

The COMBINORM brake is DC electrically powered by a control device provided by the customer as befits the specific application.

See KEB product COMBITRON for AC to DC power rectification.

6.1 Before You Begin

Prior to the initial start-up of the system, go through the following checklist to ensure the brake will function properly.

- Ensure the ordered voltage and performance data match the brake label data.
- Check to see if the brake is damaged or if there are foreign particles contaminating the area of operation or the brake air gap.
- Clean friction surfaces with a non-aggressive alcohol based brake cleaner.
- Ensure the air gap is properly adjusted and that the brake engages when switched on and releases when switched off.
- Perform the Running In Process.

→ See section Running-In Process.

⚠ CAUTION

Loss of Braking Torque!

- If the brake is damaged or contaminated, or if the switching function can no longer be guaranteed, do not put the brake into operation!

6.1.1 Running-In Process

⚠ CAUTION

Limited Braking Torque!

- The nominal braking torque is not reached until a burnishing or “running-in” period is completed.

To reach the nominal braking torque after installation or maintenance you must perform a burnishing or “running-in” process.

1. Rotate the motor with a slip speed of 25 rpm.
2. Power on the magnet and allow the brake to slip for 1 second.
3. Power off the magnet for 1 second.
4. Repeat steps 2-3 for five repetitions.
5. Stop the motor.

Test the braking torque after performing the running-in process. Repeat the process if the rated braking torque has not been reached.

7 Maintenance and Troubleshooting

⚠ CAUTION

Moving parts can crush or cut!

- Before performing maintenance or troubleshooting the brake, mechanically secure the load against unintended movements. Extra care should be given for vertical applications i.e. lifts, cranes, winches.

7.1 Maintenance

The COMBINORM is a low-maintenance brake. During routine maintenance the air gap should be tested and the brake cleaned if necessary.

7.1.1 Checking the Air Gap

⚠ WARNING

- Before adjusting the air gap, mechanically secure the load against unintended movements and disconnect the brake from the load.
- Power off the brake prior to adjusting the air gap.

The COMBINORM brake must be installed with an air gap of width X between the magnet and armature. This air gap allows the proper motion of the armature when the brake is operated and is required for the brake to function correctly. Over time the air gap will naturally increase as the friction lining is worn away. If the air gap ever exceeds the maximum air gap value the brake will suffer a strong decrease in braking torque. The air gap should be checked during routine maintenance and if it approaches X_{max} the air gap should be adjusted back to X .

If the air gap cannot be adjusted to within X_{max} , the brake should be replaced.

The table below shows the correct air gap X as well as the maximum air gap X_{max} for brakes of all sizes.

Brake Size	01	02	03	05	06	07	08	09	10	11	12
Air Gap X [mm]	0.1	0.15	0.15	0.2	0.2	0.2	0.2	0.3	0.3	0.4	0.4
Air Gap X_{max} [mm]	0.3	0.45	0.45	0.6	0.7	0.7	0.7	0.9	1.0	1.2	1.2

Table 4 Air Gap Widths and Maximums by Brake Size

To check the air gap, use a feeler gauge to check the air gap width at three points around the circumference of the brake.

7.1.2 Adjusting the Air Gap

1. Use a feeler gauge to test the air gap at several points around the brake's circumference.
 - a. If the air gap is larger than X_{max} the air gap needs to be adjusted.
2. Remove the armature and hub (if included) by reversing the installation steps for the armature assembly.
3. Adjust the air gap to width X.
 - a. For flange-mounted brakes with hubs, adjust the hub position on the shaft until the air gap is at width X.
 - b. For flange-mounted brakes without hubs, adjust customer provided hub until the air gap is at width X. Adjusting shim washers between the armature (6) and the mounting surface (7) can be used until the air gap is at width X (see Fig 9).
4. When adjustment is complete, fasten the armature assembly and hub (if included) to the shaft or mounting surface.
5. Use a feeler gauge to test the air gap to ensure the adjustment was performed correctly. Repeat steps 2-4 if the air gap is not at width X.

NOTICE

-
- Shaft-mounted brakes are shipped with a factory set air gap which cannot be adjusted. Shaft-mounted brakes require replacement if the air gap grows beyond the maximum X_{max} .
-

7.1.3 Cleaning the Brake

The COMBINORM brake should be cleaned prior to installation as well as periodically during regular maintenance. The brake should be disassembled prior to cleaning. Clean the armature and friction lining with an alcohol based brake cleaner.

⚠ WARNING

-
- The friction surfaces must be thoroughly cleaned and dried prior to returning the brake to operation.
 - Any remaining cleaning liquid or other foreign contaminants on the friction surface may result in a loss of braking torque.
-

7.2 Troubleshooting

The following are some common issues that may occur with the COMBINORM brake, as well as steps to resolving these issues.

Before performing any troubleshooting, follow all relevant safety guidelines.

→ See section Maintenance Safety Guidelines for details.



- Contact your local KEB agency for any problems not covered by this manual, or if the troubleshooting steps listed do not fully resolve the problem.

Problem	Potential Causes	Solution
Loss of Braking Torque	Incorrect Voltage	Only operate the brake with the correct voltage. See the name plate of the device for details.
	Defective Magnet Coil	Replace the brake.
	Defective Connecting Cable	Replace the brake.
	Foreign Particles in the Air Gap	Thoroughly clean the brake removing any foreign contaminants from the air gap.
	Air Gap Too Large	Adjust the air gap to be within parameters. → See Adjusting the Air Gap
	Flat Spring Overstretched	Check motion of flat spring. Replace brake if necessary.
	Friction Surfaces Contaminated	Clean friction surfaces. If friction surfaces are damaged, replace the brake.
	Thermal Overload of Brake	Replace the brake.
Delayed Braking Function	Flat Spring Overstretched	Check motion of flat spring. Replace brake if necessary.
	Foreign Partiles in the Air Gap	Thoroughly clean the brake removing any foreign contaminants from the air gap.

Table 5 Troubleshooting



- If the above troubleshooting steps do not successfully resolve the issue, contact support at KEB America Inc.

8 Appendix

8.1 Appendix A: Certification

EU DECLARATION OF CONFORMITY



Document No. / month.year: ce_mt_rns-mt-usa-a_en / 01.2019

Manufacturer:	KEB AMERICA, INC 5100 Valley Industrial Blvd.South USA – Shakopee, MN 55379 United States	
Product type:	spring applied fail safe brake electromagnet - clutch or brake clutch - brake - combinations in one housing Size Voltage category	COMBISTOP COMBINORM COMBIBOX 01 up to 14 75...440Vdc (50...690Vac)

The above given product is in accordance with the following directives of the European Union

Number:	Low voltage : 2014 / 35 / EU
Text:	Directive on the approximation of the laws of the Member States relating to all electrical equipment that has a voltage rating between 50V and 1000V AC or 75V and 1500V DC.
Number:	Hazardous Substances: 2011 / 65 / EU incl. changes 2015 / 863 / EU
Text:	Directive on the approximation of the laws of the Member States relating on the restriction of the use of certain hazardous substances in electrical and electronic equipment.

8.2 Appendix B: Technical Specifications

Specification	Description
Nominal Voltage	Standard 24 VDC +6% to -10% (Other voltages available)
Insulation Class (DIN 0580)	B (Insulation class H available as an option)
Available On Time	100%
Ambient Temperature	-20°C to 40°C

Table 6 Basic Characteristics

Weight [kg]			
Brake Size	Model XX02110-XXXX	Model XX02120/130-XXXX	Model XX02320-XXXX
01	0.1	0.1	-
02	0.1	0.1	-
03	0.15	0.15	-
05	0.2	0.25	-
06	0.3	0.3	0.8
07	0.5	0.6	1.5
08	0.9	1.1	2.7
09	1.7	2.0	4.2
10	3.2	4.0	7.8
11	5.9	7.0	-
12	11.2	13.5	-

Table 7 Brake Weight by Size



- For further technical information including dimensions, rated torques and power input, reference the KEB product catalog.

Combinorm 02 / 03 / 04 / 07				01	02	03	05	06	07	08	09	10	11	12	
Size															
M_{2N}	02/03/04 07	20 °C	[Nm]	0.5	0.75	1.5	3	7	15	30	65	130	250	500	
P₂₀	02/04 brake 03/04/07 clutch	20 °C 20 °C	[W]	6	6	8	10	12	16	21	28	38	50	65	
J															
Armature	110/210/610/710/810 120/130/230/630/730 320 170		[10 ⁻⁴ kgm ²]	0.010 0.013	0.014 0.021	0.045 0.068	0.122 0.18	0.366 0.53 0.82 0.99	1.07 1.57 2.6 2.7	3.72 5.29 10.3 9.12	10.6 15.1 27 25.4	40 50.1 101 88.9	115 159 272	311 437 814	
Rotor	110/130/140/170/610 630/640 210/230/240/710/730/740 810			0.025 0.027	0.035 0.038	0.15 0.17	0.375 0.4	0.825 0.9 1.02	2.38 2.6 3.05	7.25 8 8.76	21.9 24 26	67.4 73 82.5	200 220 230	450 500 520	
W_{Rmax}	02/03/04		[10 ⁴ J]	0.04	0.05	0.08	0.12	0.19	0.31	0.48	0.75	1.25	2	2.9	
W_{R0.1mm}	02/03/04		[10 ² J]	0.23	0.3	0.43	0.63	0.95	1.63	2.53	4.09	6.66	10.4	16.3	
P_{Rmax}	02/04 brake 03/04 clutch		[J/s]	12.8 20.3	18.6 28.6	26.9 40.6	38.9 58.3	58.3 80.6	79.2 114	114 161	164 228	236 322	339 458	489 647	
X_{nmax} 20°	02/03/04 07		[mm]	0.3	0.45	0.45	0.6	0.7 0.15	0.7 0.2	0.7 0.2	0.9 0.2	1.0 0.25	1.2	1.2	
X	02/03/04			0.1	0.15	0.15	0.2	0.2	0.2	0.2	0.3	0.3	0.4	0.4	
n_{max}	02/03/04/07 exception clutch! 03.610/630/640		[rpm]	10,000 1,500	10,000 1,500	10,000 1,500	10,000 1,500	8,000 1,500	6,000 1,500	5,000	4,000	3,000	3,000	2,000	
Switching times															
Brake 02/04	t ₂ DC t ₂ AC nominal voltage t ₁₁ = t ₁ = 3 x nominal voltage t ₁₁ = t ₁ =		[ms]	3 17 2 5 1 3	4 20 3 8 2 4	5 25 3 8 2 4	8 40 5 17 3 8	10 70 6 24 3 11	15 95 8 38 4 17	50 240 10 42 5 20	85 300 13 48 6 22	100 400 15 85 8 38	140 600 23 118 10 50	200 800 35 155 16 76	
Clutch 03/04	t ₂ DC t ₂ AC nominal voltage t ₁₁ = t ₁ = 3 x nominal voltage t ₁₁ = t ₁ =		[ms]	5 17 4 10 2 5	6 19 5 14 2 6	7 22 7 17 3 7	10 30 10 32 5 16	14 39 14 48 6 22	19 61 18 74 8 33	40 115 23 81 10 37	68 220 25 90 12 42	100 400 29 161 14 69	130 650 37 201 16 91	200 900 55 295 25 125	

Legend

M _{2N}	rated torque after running in process	[Nm]	t	time	[ms]
M _{ref}	required torque	[Nm]	t ₁	Engaging time Time from connecting the current the rated torque is attained	[ms]
J	moment of inertia	[10 ⁻⁴ kgm ²]	t ₁₁	Engaging delay time: Time from connecting the current until the torque rises	[ms]
P ₂₀	power at 20 °C	[W]	t ₂	Release time: Time from disconnecting the current until 0.1 M _{2N}	[ms]
n _{max}	maximum speed	[min ⁻¹]			
X _{nmax}	rated air gap	[mm]			
X _n	clearance at which an adjustment is recommended	[mm]			
W _{Rmax}	permissible friction per switching operation	[10 ⁴ J]			
W _{R0.1}	friction work up to 0,1 mm wear	[10 ² J]			
P _{Rmax}	permissible friction work per second	[J/s]			
I	magnet-rated current	[A]			

Table 8 Technical Specifications

9 Revision History

Chapter	Change	Date
All	Initial Publication	12/2021

Austria | KEB Antriebstechnik Austria GmbH
Ritzstraße 8 4614 Marchtrenk Austria
Tel: +43 7243 53586-0 Fax: +43 7243 53586-21
E-Mail: info@keb.at Internet: www.keb.at

Belgium | KEB America, Inc.
Herenveld 2 9500 Geraardsbergen Belgium
Tel: +32 544 37860 Fax: +32 544 37898
E-Mail: vb.belgien@keb.de Internet: www.keb.de

Brazil | KEB SOUTH AMERICA - Regional Manager
Rua Dr. Omar Pacheco Souza Riberio, 70
CEP 13569-430 Portal do Sol, São Carlos Brazil
Tel: +55 16 31161294 E-Mail: roberto.arias@keb.de

France | Société Française KEB SASU
Z.I. de la Croix St. Nicolas 14, rue Gustave Eiffel
94510 La Queue en Brie France
Tel: +33 149620101 Fax: +33 145767495
E-Mail: info@keb.fr Internet: www.keb.fr

Germany | **Headquarters**
KEB Automation KG
Südstraße 38 32683 Barntrup Germany
Telefon +49 5263 401-0 Telefax +49 5263 401-116
E-Mail: info@keb.de Internet: www.keb.de

Germany | **Geared Motors**
KEB Antriebstechnik GmbH
Wildbacher Straße 5 08289 Schneeberg Germany
Telefon +49 3772 67-0 Telefax +49 3772 67-281
Internet: www.keb-drive.de E-Mail: info@keb-drive.de

Italia | KEB Italia S.r.l. Unipersonale
Via Newton, 2 20019 Settimo Milanese (Milano) Italia
Tel: +39 02 3353531 Fax: +39 02 33500790
E-Mail: info@keb.it Internet: www.keb.it

Japan | KEB Japan Ltd.
15 - 16, 2 - Chome, Takanawa Minato-ku
Tokyo 108 - 0074 Japan
Tel: +81 33 445-8515 Fax: +81 33 445-8215
E-Mail: info@keb.jp Internet: www.keb.jp

P.R. China | KEB Power Transmission Technology (Shanghai)
Co. Ltd. No. 435 QianPu Road Chedun Town Songjiang District
201611 Shanghai P.R. China
Tel: +86 21 37746688 Fax: +86 21 37746600
E-Mail: info@keb.cn Internet: www.keb.cn

Republic of Korea | KEB America, Inc.
Room 1709, 415 Missy 2000 725 Su Seo Dong
Gangnam Gu 135- 757 Seoul Republic Korea
Tel: +82 2 6253 6771 Fax: +82 2 6253 6770
E-Mail: vb.korea@keb.de

Russian Federation | KEB RUS Ltd.
Lesnaya str, house 30 Dzerzhinsky MO
140091 Moscow region Russian Federation
Tel: +7 495 6320217 Fax: +7 495 6320217
E-Mail: info@keb.ru Internet: www.keb.ru

Spain | KEB America, Inc.
c / Mitjer, Nave 8 - Pol. Ind. LA MASIA
08798 Sant Cugat Sesgarrigues (Barcelona) Spain
Tel: +34 93 8970268 Fax: +34 93 8992035
E-Mail: vb.espana@keb.de

United Kingdom | KEB (UK) Ltd.
5 Morris Close Park Farm Industrial Estate
Wellingborough, Northants, NN8 6 XF United Kingdom
Tel: +44 1933 402220 Fax: +44 1933 400724
E-Mail: info@keb.co.uk Internet: www.keb.co.uk

United States | KEB America, Inc
5100 Valley Industrial Blvd. South
Shakopee, MN 55379 United States
Tel: +1 952 2241400 Fax: +1 952 2241499
E-Mail: info@kebamerica.com Internet: www.kebamerica.com



MORE KEB PARTNERS WORLDWIDE:

www.keb.de/company/representatives-agencies



Automation with Drive

www.kebamerica.com

KEB America, Inc. 5100 Valley Industrial Blvd S Shakopee, MN 55379 Tel. +1 952-224-1400 E-Mail: info@kebamerica.com