



COMBITRON

INSTRUCTION MANUAL | Type 91 Rectifier

Original Manual
COMBITRON Type 91
Document 20267590 USA 00
Material No. 00910EB-K000 Rev 1E







1 Preface

The hardware described in this document are products of KEB America, Inc. The information contained in this document is valid at the time of publishing. KEB reserves the right to update this document in response to misprints, mistakes or technical changes.



1.1 Warning Signs and Key Symbols

Certain procedures within this document can cause safety hazards during the installation or operation of the device. Refer to the safety warnings in this document when performing these procedures. Safety signs are also located on the device where applicable. A safety warning is marked by one of the following warning signs:

	➤ Dangerous situation which will cause death or serious injury if this safety warning is ignored.
	➤ Hazardous situation which may cause death or serious injury if this safety warning is ignored.
	➤ Hazardous situation which may cause minor or moderate injury if this safety warning is ignored.
	➤ Situation which may cause property damage if this safety warning is ignored.
<u>RESTRICTION</u>	➤ Used when the following statements depend on certain conditions or are only valid for certain ranges of values.
	➤ Used for informational messages or recommended procedures.

1.2 More Symbols

1. Numbered list items begin action steps.
- Enumerations are marked with boxes.
- Thin arrows indicate cross references to another chapter or another page.

	Further documentation can be found at https://www.kebamerica.com Document search on www.kebamerica.com/em-documents/	
---	---	---

1.3 Laws and Requirements



KEB Automation KG has certified the product against the US, Canadian and European standards. Additionally KEB Automation KG provides the EC declaration of conformity that the product complies with the essential safety requirements.

The UL, CSA and CE marks are located on the name plate when applicable. The EC declaration of conformity can be downloaded on demand via our website.

→ Further information is provided in Appendix A: Certification.

1.4 Warranty

KEB America Inc provides a limited warranty on all products. This warranty can be found in the terms and conditions at our website.

	KEB America, Inc. Terms and Conditions Terms and Conditions	
---	--	---

Further agreements or specifications require written confirmation from KEB America, Inc.

1.5 Support and Liability

It is not possible to cover every potential application of our device in a single manual. If you require further information or if problems occur which are not covered in this document, you can request the necessary information via KEB America, Inc. or the local KEB Automation KG agency.

The use of our products in the target application is beyond our control and therefore exclusively the responsibility of the machine manufacturer, system integrator or customer.

The information contained in this document, as well as any user-specific advice in spoken or written form or generated through testing, is provided to best of our knowledge and is considered for informational purposes only. KEB America, Inc. bears no responsibility or liability for the accuracy of the information listed above, nor for any violation of industrial property rights committed by a third-party in relation to this information.

Selection of the most suitable product for any given application is the responsibility of the machine manufacturer, system integrator or customer.

Evaluation of the product can only be performed by the machine manufacturer in combination with the application. Any tests performed must be repeated every time any part of the hardware or software is modified, or any time the unit adjustment is changed.

1.6 Copyright

The customer may use the information contained within this document for internal purposes only. Copyright of this document is held by KEB America, Inc. and remains valid in its entirety.

Other wordmarks or/and logos are trademarks (™) or registered trademarks (®) of their respective owners and are listed in a footnote at the first occurrence.

Table of Contents

1	Preface	3
1.1	Warning Signs and Key Symbols	3
1.2	More Symbols.....	3
1.3	Laws and Requirements.....	4
1.4	Warranty.....	4
1.5	Support and Liability	4
1.6	Copyright	4
	Table of Contents	5
1.7	Standards for COMBITRON 91.....	7
2	Safety Instructions	8
2.1	Target Audience	8
2.2	Specified Application.....	9
2.3	General Safety Guidelines.....	9
2.4	Electrical Safety Guidelines	9
3	Product Description	10
3.1	Scope of this Manual	10
3.2	Rectifier Components	10
3.3	Model Numbers	10
3.4	Technical Data.....	11
3.4.1	Rated IEC Operating Values.....	11
3.4.2	Rated UL Operating Values.....	11
3.4.3	Reduction of Output Current in Accordance with UL	12
3.4.4	Dimensions	12
4	Installation	13
4.1	AC vs DC Switching.....	13
4.1.1	AC Side Switching	13
4.1.2	DC Side Switching	13
4.1.3	AC vs DC Switching Summary	14
4.2	Connection Diagrams	14

4.3 Maximum Switching Cycles – DC Side Switching..... 19

5 Appendix..... 20

5.1 Appendix A: Certification 20

6 Revision History..... 21

7 Notes:..... 22

1.7 Standards for COMBITRON 91

- IEC 364
- CENELEC HD 384
- DIN VDE 0100
- DIN VDE 0160 (EN 50178)
- DIN VDE 0113 (EN 60204)
- UL 508
- NFPA 70
- NFPA 79

2 Safety Instructions

The COMBITRON is designed and constructed with state-of-the-art technology in accordance with recognized safety rules and regulations. Improper use of this device may cause hazards to life and limb of the user or third-parties, or damage to the application and other material property.

The following safety instructions have been created by KEB America, Inc. for the COMBITRON. These instructions can be supplemented by local, country- or application-specific safety instructions where relevant.

Violation of the safety instructions in this manual will result in the loss of any liability claims.

NOTICE

Stay Safe! Stay Informed!

- Read the instruction manual prior to operating the device!
 - Follow all safety and warning instructions!
 - If you are unsure of any part of these instructions, please contact KEB prior to operating the device!
-

2.1 Target Audience

This manual is intended exclusively for the use of qualified electrical/mechanical technicians. Qualified technicians for the purpose of this document must meet the following:

- Must have fully read and understood the safety instructions contained in this manual.
- Must be familiar with the installation and assembly of electrical products.
- Must be familiar with the installation and operation of the product as specified in this manual.
 - See the Installation chapter for details.
- Must fully understand the specified application of the product.
 - See the Specified Application section for details.
- Must be familiar with the hazards and risks of electromechanical brake technology.
- Must be familiar with appropriate electrical and safety codes:
 - **US:** NFPA 70 National Electric Code (NEC)
 - **Canada:** Canadian Electric Code, C22 Part 1 (CEC)
- Must be familiar with national safety regulations (e.g. OSHA Title 29 CFR):
 - See the Standards for COMBITRON 91 section for details.

2.2 Specified Application

The operational reliability of the COMBITRON is only guaranteed when the device is used for the specified application. In this context, specified application means the purpose for which the COMBITRON was ordered and configured.

Any use of the COMBITRON outside of this specified application is considered at the user's own risk. Such unintended uses may pose unforeseeable risks or hazards. KEB America, Inc. retains no liability for any damage or injury resulting from the use of a COMBITRON outside of the specified application.

2.3 General Safety Guidelines

Carefully observe the following safety guidelines before installation or operation of the device.

- Only trained personnel should operate the COMBITRON.
- Immediately remove the COMBITRON from operation in case of a malfunction.
- Malfunctions should be corrected by trained personnel before returning the COMBITRON to operation.
- Never use the COMBITRON in potentially explosive environments.
- The COMBITRON may not be modified or altered in any way not intended by KEB America, Inc.

2.4 Electrical Safety Guidelines

⚠ DANGER

Rick of electrical shock!

- Turn off the power supply and secure it against switching on prior to any work on the device.
 - Wait until the system has come to a complete stop prior to any work on the device.
 - Never bridge branch circuit protection devices.
-

- Observe all relevant safety standards during the electrical installation.
 - See the Standards for COMBITRON 91 section for details specific to the product.
- Use only wire gauges and fuses rated for the power requirements of the device.
- Ensure new or existing circuits meet NEC or applicable local requirements.
- All "Safe" isolated circuits must include other protective measures, e.g. double insulation or grounded shielding when run together with high voltage circuits in accordance with UL61800-5-1 / IEC61800-5-1.
- When using components with isolated inputs/outputs, equipotential bonding must be used between the connected components. Failure to provide adequate equipotential bonding may result in the destruction of the components by equalizing currents.

3 Product Description

3.1 Scope of this Manual

The KEB COMBITRON 91 is a rectification unit designed exclusively for supplying energy to electromechanical clutches and brakes. The unit employs a rectifier to convert incoming AC into DC. The units utilize rectifiers configured as either full-wave or half-wave circuits in order to match the supply voltage to the coil voltage. The units feature a compact design which is small enough to fit inside most motor terminal boxes. The rectifiers are rated for a wide temperature range to support use inside the motor terminal box. The COMBITRON can be switched either on the AC (line) side or the DC (load) side while internal MOVs offer protection for the switching contacts.

3.2 Rectifier Components

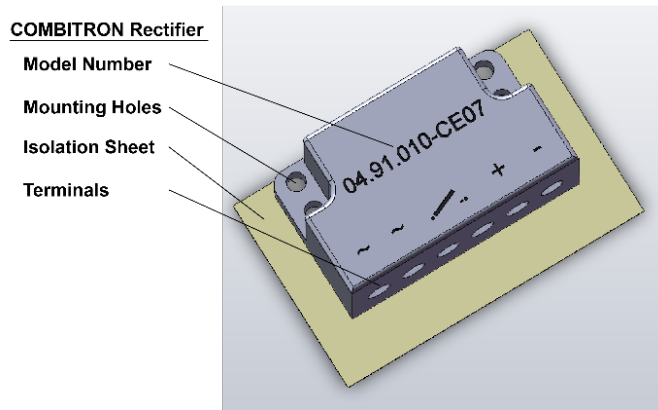

3.3 Model Numbers

COMBITRON model numbers take the following format:

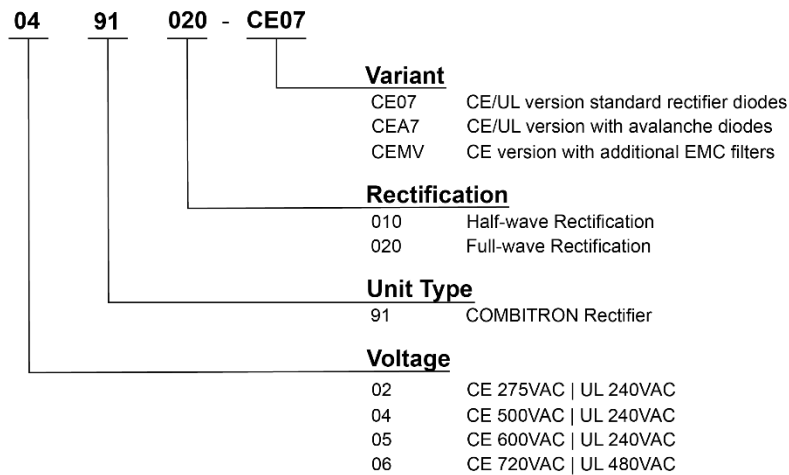

3.4 Technical Data

3.4.1 Rated IEC Operating Values

To find the rating for a specific COMBITRON rectifier, look up the model number on the following table with the format [first row]-[second row]-[third row].

Example: 0291010-CEMV = 0291 010 CEMV

COMBITRON Model Number	Units	0291		0491				0591	0691		
		010		020		010		020		010	010
		CEMV	CE07	CE07	CE07	CEA7	CE07	CEA7	CE09	CE09	
Maximum Input Voltage	VAC	275		500				600	720		
Maximum Interrupting Voltage	VAC	450		900				1000	1600		
Input Current	A										
Mains Frequency	Hz	50/60 ±2									
Rated Output Voltage	VDC	0.45·U _{in}	0.9·U _{in}	0.45·U _{in}	0.9·U _{in}	0.45·U _{in}					
Rated Output Current	A	1.2	2.0	1.2	2.0	1.2					
DC Contact Switching	-	Yes		Yes				External	External		
Type of Protection	-	IP20									
Climatic Category	3K3	Extended to -10 to 45°C (up to max 85°C with derating)									
Terminal Tightening Torque	Nm	0.4		0.5				0.4	0.5		
Permissible Cable Cross-section	mm ²	1.2 to 2		0.8 to 2				1.2 to 2	0.8 to 2		
Dimensions (See 3.4.4)	Figure	2	1	1	2		1	2			

3.4.2 Rated UL Operating Values

To find the rating for a specific COMBITRON rectifier, look up the model number on the following table with the format [first row]-[second row]-[third row].

Example: 0291010-CEMV = 0291 010 CE07

COMBITRON Model Number	Units	0291		0491				0591	0691		
		010		020		010		020		010	010
		CE07	CE07	CE07	CEA7	CE07	CEA7	CE09	CE09		
Input Voltage	VAC	240		240				240	480		
Input Current	A	0.6	1.2	0.6	1.2	0.6	0.6	0.6			
Output Voltage	VDC	108	216	108	216	108	216	216			
Output Current	A	1.2									
DC Contact Switching	-	Yes		Yes				External	External		
Type of Protection	-	IP20									
Climatic Category	3K3	Extended to -10 to 45°C (up to max 85°C with derating)									
Terminal Tightening Torque	Lb.in	3.5		4.5				3.5	3.5		
Permissible Cable Cross-section	AWG	16 to 18		14 to 18				14 to 18	14 to 18		
For surrounding air temperatures ≤ 60°C		Use 60/75°C wires									
For surrounding air temperatures ≥ 60°C		Use at least 90°C Wires									
Dimensions (See 3.4.4)	Figure	1	1	2		1	2				
These devices shall be protected by external Class CC fuses rated maximum 5A for each ungrounded conductor.											

3.4.3 Reduction of Output Current in Accordance with UL

Site altitude above sea level	≤1000m	100% Nominal Current
	>1000m	-1% Nominal Current per 100m (max. 2000m)
Maximum surrounding air temperature	45°C	1.2A output current (nominal current)
	60°C	0.9A output current
	75°C	0.6A output current
	85°C	0.5A output current

3.4.4 Dimensions

Figure 1 – Small Housing		Figure 2 – Large Housing	
Isolation Sheet 0091999-9035		Isolation Sheet 04591999-6038	
	A clearance distance of min. 9.5mm to the terminal must be observed when assembling on conductive, grounded surface. The included isolation sheet must be sub-mounted if the minimum clearance distance above is not given.		
	AC Voltage Input		
	DC Voltage Output		
	Switching Input for DC Side. When terminals are not included, the switch contact must be wired externally. See wiring diagram.		
<i>All dimensions in mm</i>			

4 Installation

Before installing the COMBITRON rectifier, it is important to determine whether to install the on/off switch for the brake or clutch on the AC or DC side of the rectifier.

4.1 AC vs DC Switching

There are two methods of switching brakes and clutches. These are referred to as AC side or DC side and indicate on which side of the rectifier the switch is located. Each method has advantages and disadvantages which may impact the performance of the brake or clutch in the actual application. The following sections provide more detail on the two methods of switching. It is up to the end user to determine which method of switching best suits their application.

4.1.1 AC Side Switching

AC side switching places the switching mechanism on the AC (line) side of the rectifier. The high voltage AC is switched on and off by a relay or contactor. This switch is normally placed on all non-grounded conductors after the branch circuit fuse(s). If the rectifier has a switch contact, a wire jumper is installed into the terminals. Since the switch is on the AC side, the rectifier provides a path for the inductive current from the brake or clutch to dissipate. As a result there is very little arcing on the relay contacts when they open and the load can be considered a resistive load. This means relatively small control relays can be used to switch the brake or clutch on and off.

The rating of the switching contacts shall be at least equal to the rated AC voltage which is applied and the current rating shall be 5 amps, AC1 contact rating.

The disadvantage however is that because the rectifier allows the inductive current to dissipate slowly, the switching time of the brake or clutch is delayed. As an example, with a COMBISTOP spring applied brake, this delay time is the time between the switching event and the onset of brake torque. In larger brakes with high inductance, this delay time can exceed 1 second.

4.1.2 DC Side Switching

DC side switching places the switching mechanism on the DC (load) side of the rectifier. The high voltage DC is switched on and off using a DC rated contactor. The contactor is either wired to the switch contacts on the rectifier, or is wired in series with the brake. The contactor must be rated for switching the rated DC voltage and current, but in addition must be capable of breaking the circuit without failure resulting from the high voltage created by the inductance in the brake coil.

The varistors which are internal to the rectifier will clamp the voltage across the switch contact, however the instantaneous peak value of the voltage may exceed 1000V. Therefore it is important to take this into consideration when selecting the switching contactor. Generally for DC side switching the minimum contact ratings are 300VDC 9A, AC3 rating.

The advantage to DC side switching is the speed of the brake reaction. The delay time associated with brake engagement can be reduced by over a factor of ten compared to AC side switching. This results in faster control of the mechanical system which may provide better safety.

4.1.3 AC vs DC Switching Summary

The following table shows a summary of pros and cons of AC vs DC side switching for ease of reference. Select the type of switching that best fits the application.

Category	AC	DC
Brake* release time	+	+
Brake* engage time	-	+
Small switching contactor	+	-
Minimal arcing across switch contact (reduced wear and tear)	+	-
Higher safety for hoists and lifts	-	+

*refers to a KEB COMBISTOP spring applied brake

4.2 Connection Diagrams

The voltage rating of the clutch or brake coil and the available supply voltage will determine what type of rectifier is required. In general the DC output voltage from a full-wave rectifier is 0.9 times the AC input, whereas the DC output voltage from a half-wave rectifier is 0.45 times the AC input. The correct rectifier must be selected based on the rated voltages of the supply and load. The following diagrams provide examples of the most common scenarios, however not all possibilities are covered. Please consult KEB for further assistance if the configuration needed is not found below.

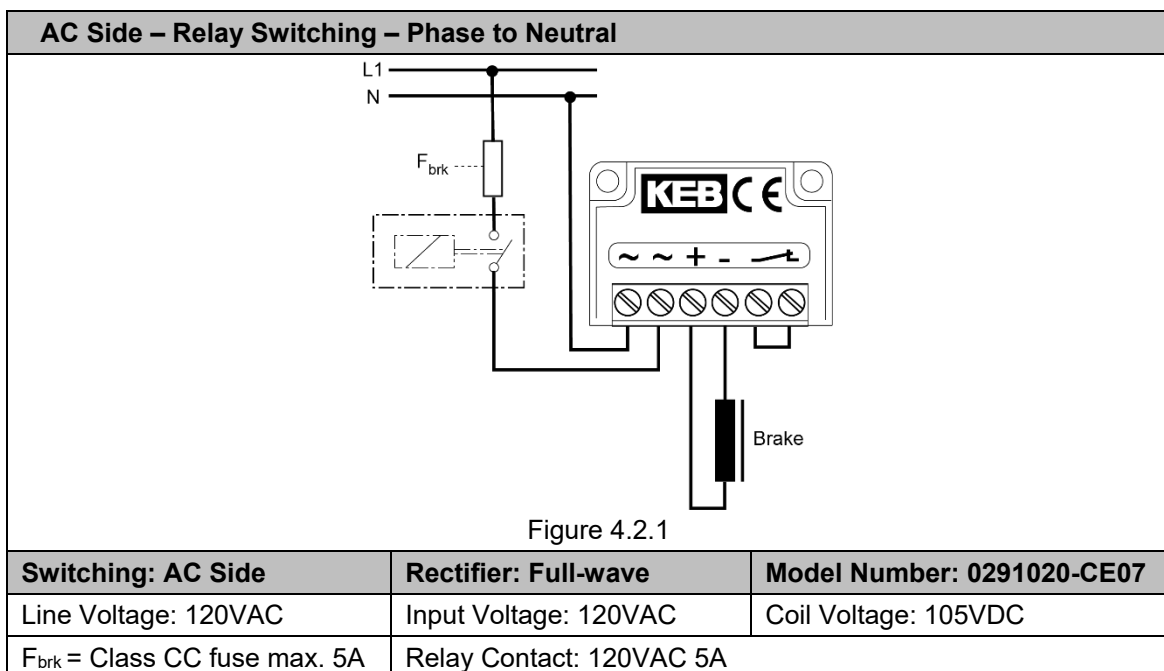

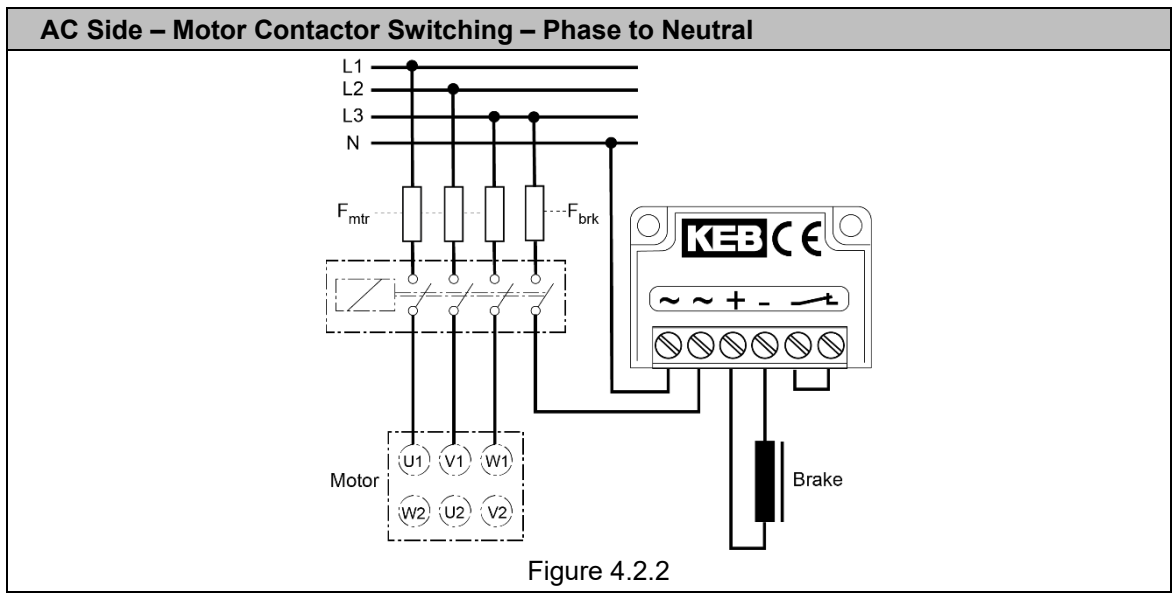

Switching: AC Side	Rectifier: Full-wave	Model Number: 0291020-CE07
Line Voltage: 208/120VAC	Input Voltage: 120VAC	Coil Voltage: 105VDC
	Rectifier: Full-wave	Model Number: 0491020-CE07
Line Voltage: 400/230VAC	Input Voltage: 230VAC	Coil Voltage: 205VDC
F _{brk} = Class CC fuse max. 5A	Motor contactor sized for motor, min 5A	

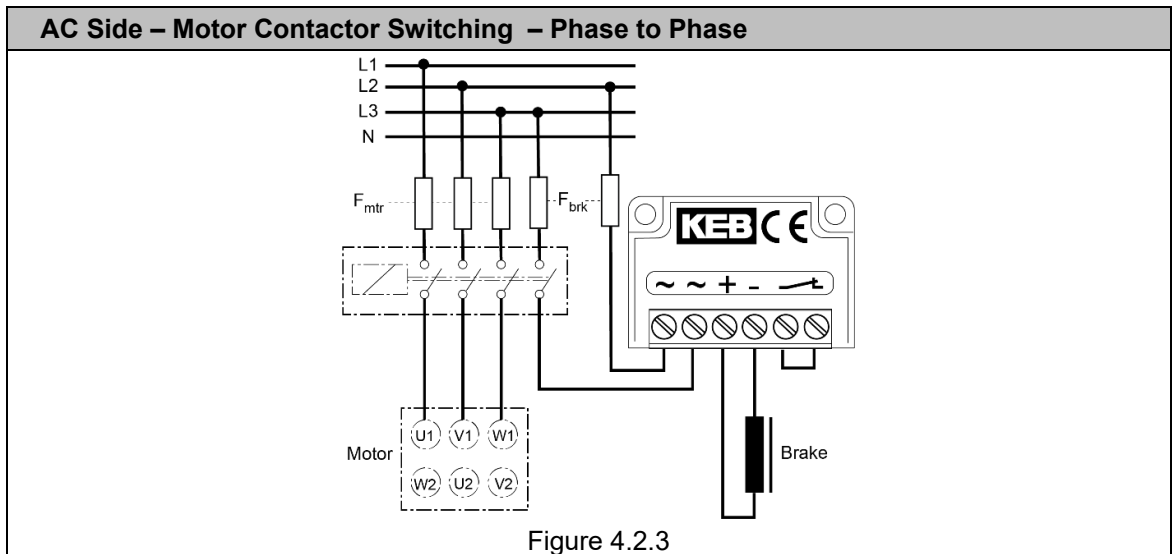

Switching: AC Side	Rectifier: Full-wave	Model Number: 0491020-CE07
Line Voltage: 208VAC	Input Voltage: 208VAC	Coil Voltage: 180VDC
Line Voltage: 230VAC	Input Voltage: 230VAC	Coil Voltage: 205VDC
F _{brk} = Class CC fuse max. 5A	Motor Contactor sized for motor, min 5A	

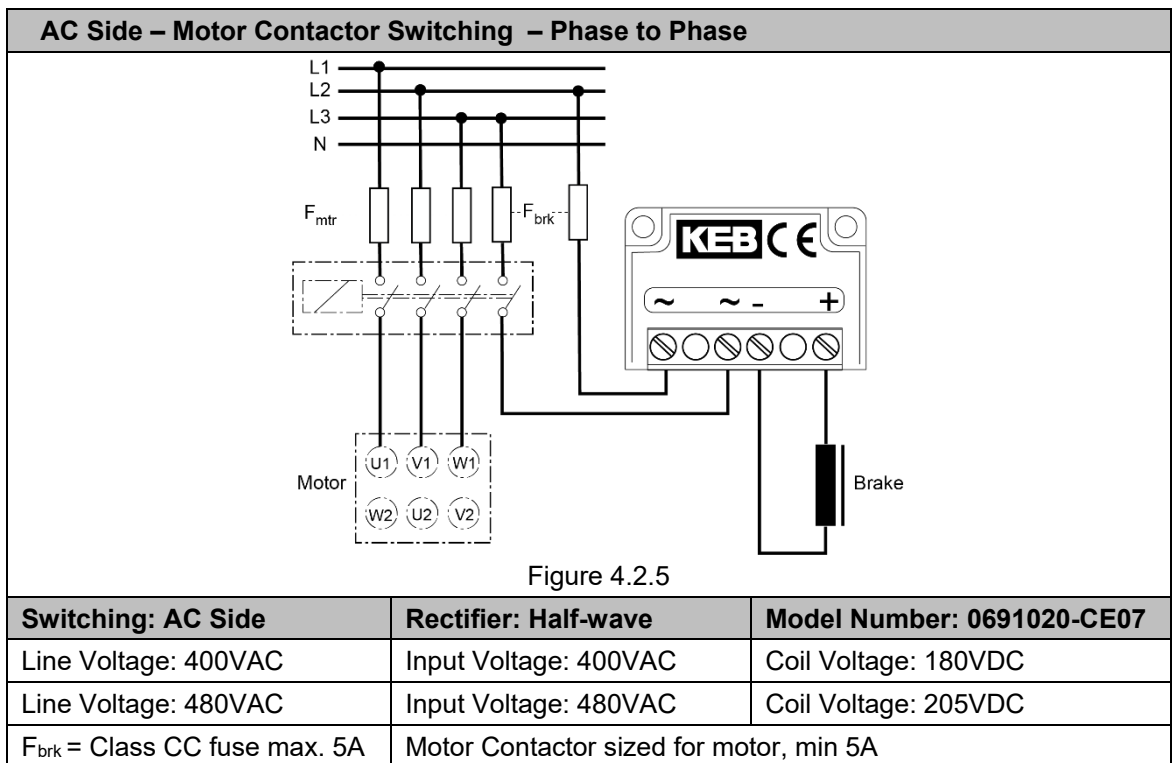
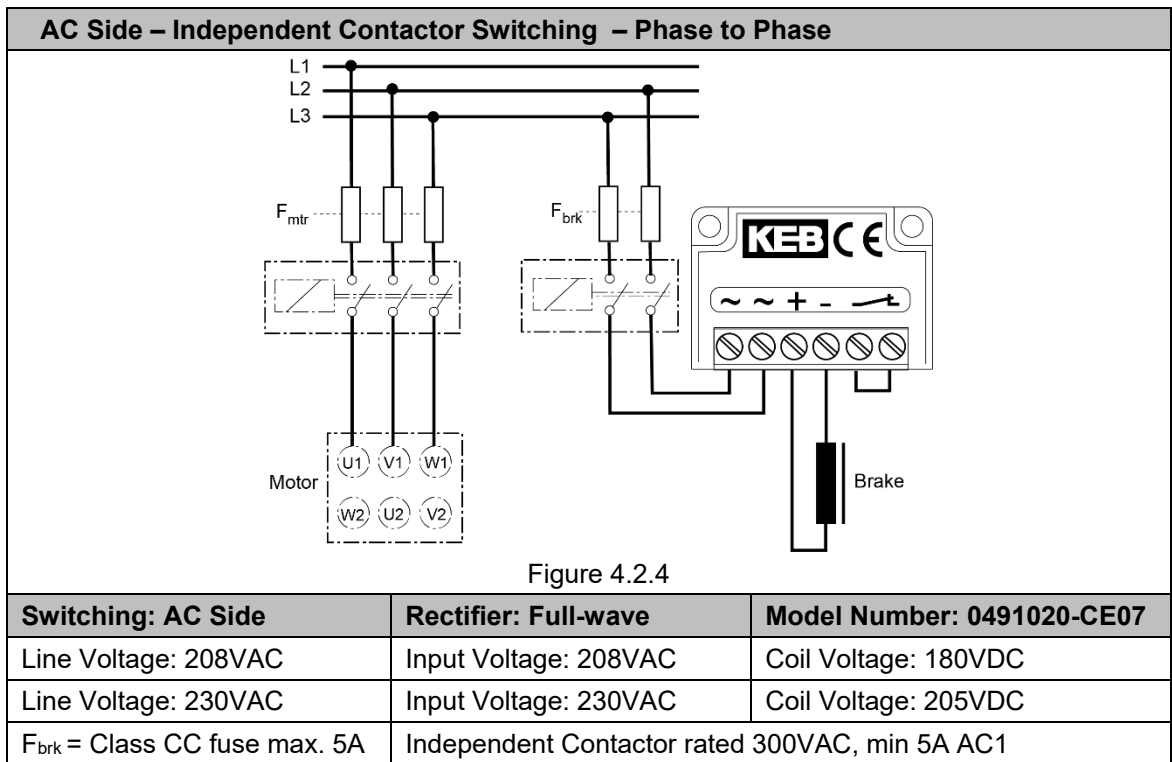

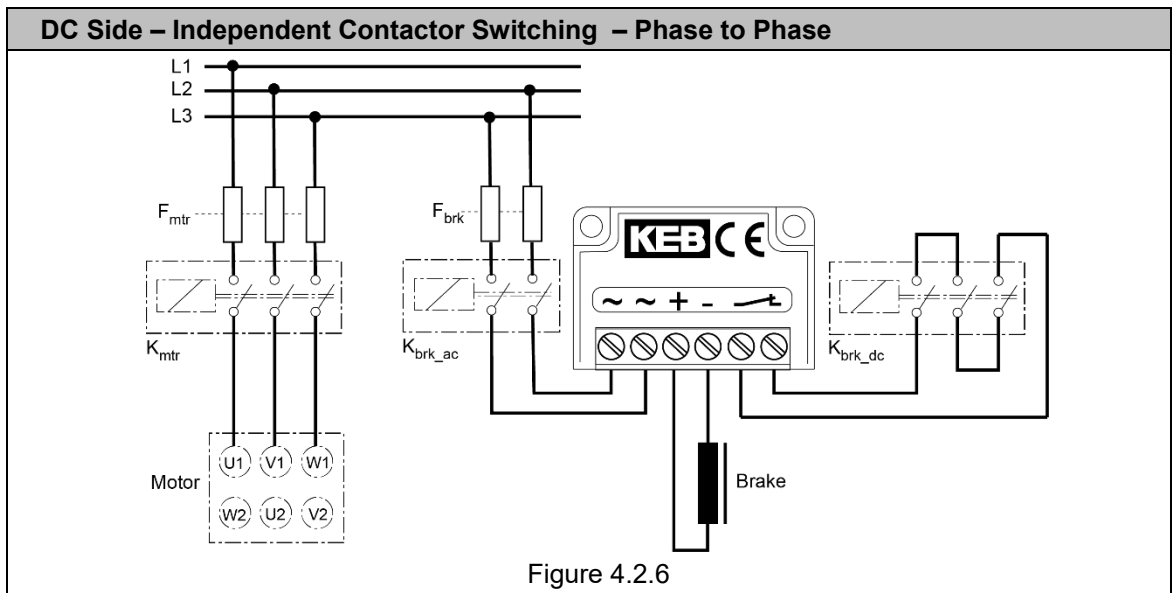

Switching: DC Side	Rectifier: Half-wave	Model Number: 0491010-CE07
Line Voltage: 208VAC	Input Voltage: 208VAC	Coil Voltage: 95VDC
Line Voltage: 230VAC	Input Voltage: 230VAC	Coil Voltage: 105VDC
	Rectifier: Full-wave	Model Number: 0491020-CE07
Line Voltage: 208VAC	Input Voltage: 208VAC	Coil Voltage: 180VDC
Line Voltage: 230VAC	Input Voltage: 230VAC	Coil Voltage: 205VDC
F _{brk} = Class CC fuse max. 5A	K _{brk_dc} = min 300VDC 9A AC3	
Optional redundant contactor for safety	K _{brk_ac} = min 300VAC 5A AC1	

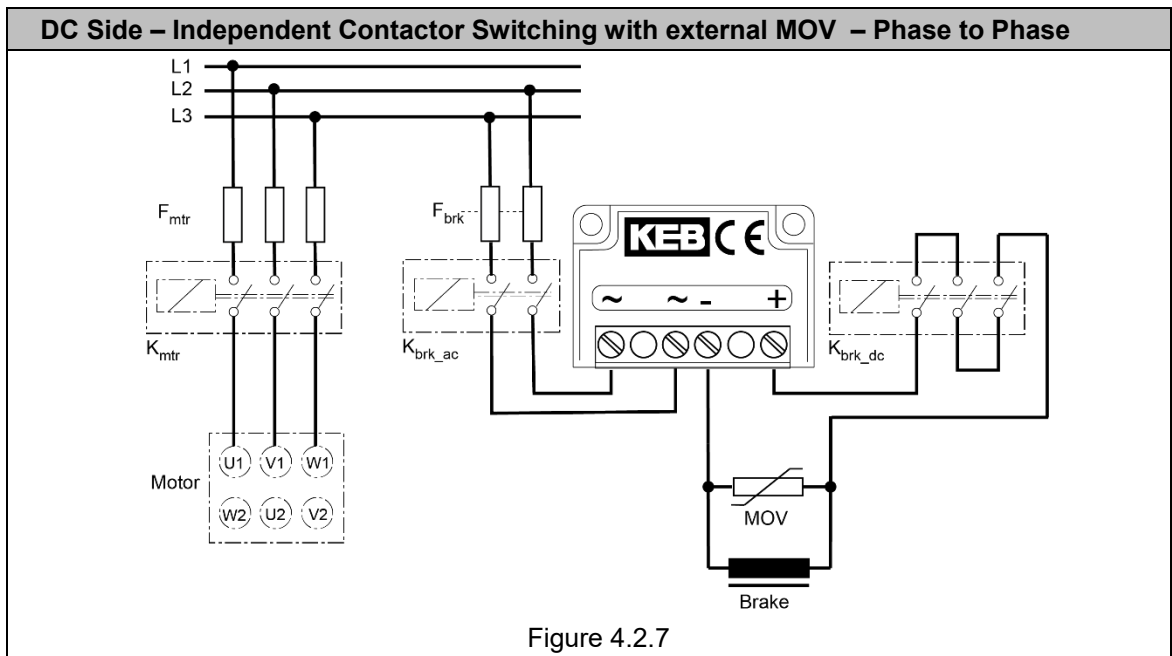

Switching: DC Side	Rectifier: Half-wave	Model Number: 0691010-001U
Line Voltage: 400VAC	Input Voltage: 400VAC	Coil Voltage: 180VDC
Line Voltage: 480VAC	Input Voltage: 480VAC	Coil Voltage: 205VDC
F _{brk} = Class CC fuse max. 5A	K _{brk_dc} = min 600VDC 9A AC3	MOV: 625Vrms / 1000Vpk / 500J <i>Installed at the brake</i>
Optional redundant contactor for safety	K _{brk_ac} = min 600VAC 5A AC1	

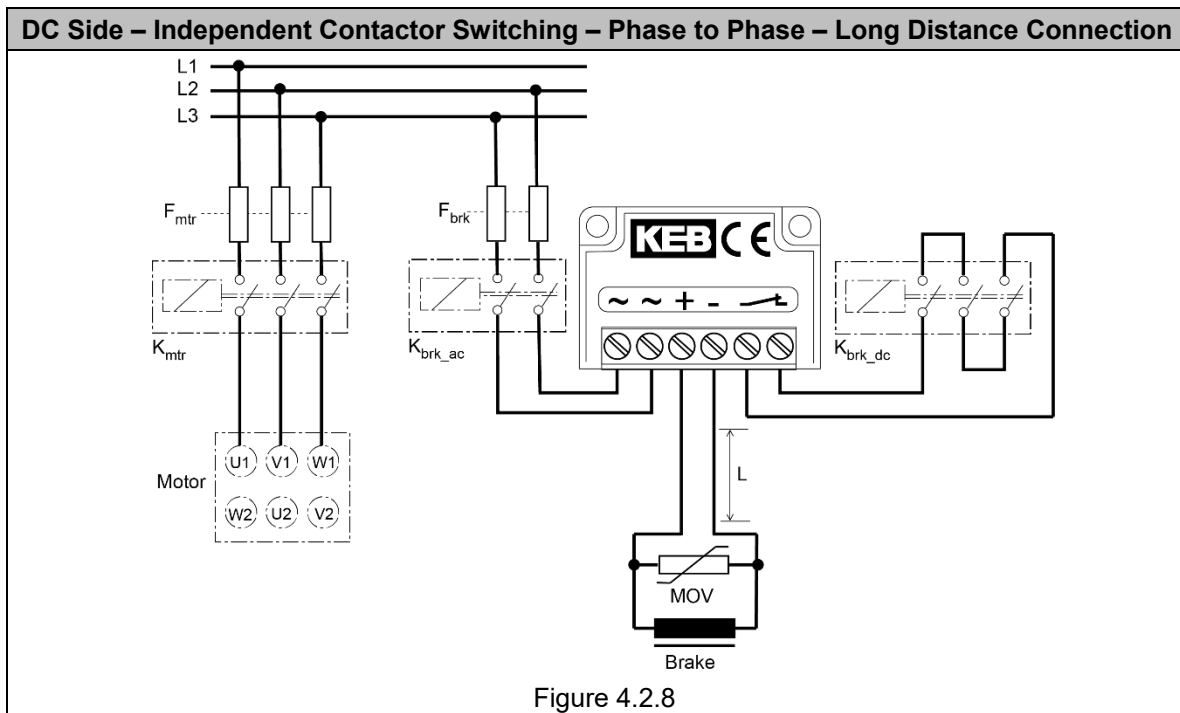

Switching: DC Side	Rectifier: Half-wave	Model Number: 0491010-CE07
Line Voltage: 208VAC	Input Voltage: 208VAC	Coil Voltage: 95VDC
Line Voltage: 230VAC	Input Voltage: 230VAC	Coil Voltage: 105VDC
F _{brk} = Class CC fuse max. 5A	K _{brk_dc} = min 300VDC 9A AC3	MOV: 0038611-001U 625Vrms / 1000Vpk / 500J <i>Installed at the brake</i>
Optional redundant contactor for safety	K _{brk_ac} = min 300VAC 5A AC1	

When DC side switching and the conductor length is greater than 20m it is possible a higher than normal voltage can appear at the rectifier. In this scenario an additional MOV is required to clamp the voltage at the brake.

4.3 Maximum Switching Cycles – DC Side Switching

The maximum cycle rate is defined by the energy storage of the magnetic coil in the brake. When the brake is de-energized via the DC side switching, some of the energy is absorbed by the varistors in the rectifier. High cycle rates together with large brake coils can result in an overload of the rectifier.

In these cases, the following MOVs may be used externally, connected in parallel to the brake as shown in figure 4.2.8. The voltage rating of the MOV is dependent on the supply voltage of the rectifier. The following combinations are recommended.

Supply Voltage	KEB Material Number	Varistor Voltage
120V, 208V, 230V, 240V	0090045-2753	275VACrms
400V, 480V	0090045-6255	625VACrms

5 Appendix

5.1 Appendix A: Certification



CE Conformity

The COMBITRON 91 meets the requirements of the Low-Voltage Directive 2014/35/EU. Rectifier 0291010-CEMV can exclusively be used on requirements in accordance with the EMC directive 2014/30/EU (or consultation with KEB).



UL Recognition

These devices have been investigated by UL according to United States Standard UL508 (Industrial Control Equipment), and to the Canadian Standard CSA C22.2 No. 14 (Industrial Control Equipment).

6 Revision History

Chapter	Change	Date
All	Initial Publication	5/2021

7 Notes:

Austria | KEB Antriebstechnik Austria GmbH
Ritzstraße 8 4614 Marchtrenk Austria
Tel: +43 7243 53586-0 Fax: +43 7243 53586-21
E-Mail: info@keb.at Internet: www.keb.at

Belgium | KEB America, Inc.
Herenveld 2 9500 Geraardsbergen Belgium
Tel: +32 544 37860 Fax: +32 544 37898
E-Mail: vb.belgien@keb.de Internet: www.keb.de

Brazil | KEB SOUTH AMERICA - Regional Manager
Rua Dr. Omar Pacheco Souza Riberio, 70
CEP 13569-430 Portal do Sol, São Carlos Brazil
Tel: +55 16 31161294 E-Mail: roberto.arias@keb.de

France | Société Française KEB SASU
Z.I. de la Croix St. Nicolas 14, rue Gustave Eiffel
94510 La Queue en Brie France
Tel: +33 149620101 Fax: +33 145767495
E-Mail: info@keb.fr Internet: www.keb.fr

Germany | **Headquarters**
KEB Automation KG
Südstraße 38 32683 Barntrup Germany
Telefon +49 5263 401-0 Telefax +49 5263 401-116
E-Mail: info@keb.de Internet: www.keb.de

Germany | **Geared Motors**
KEB Antriebstechnik GmbH
Wildbacher Straße 5 08289 Schneeberg Germany
Telefon +49 3772 67-0 Telefax +49 3772 67-281
Internet: www.keb-drive.de E-Mail: info@keb-drive.de

Italia | KEB Italia S.r.l. Unipersonale
Via Newton, 2 20019 Settimo Milanese (Milano) Italia
Tel: +39 02 3353531 Fax: +39 02 33500790
E-Mail: info@keb.it Internet: www.keb.it

Japan | KEB Japan Ltd.
15 - 16, 2 - Chome, Takanawa Minato-ku
Tokyo 108 - 0074 Japan
Tel: +81 33 445-8515 Fax: +81 33 445-8215
E-Mail: info@keb.jp Internet: www.keb.jp

P.R. China | KEB Power Transmission Technology (Shanghai)
Co. Ltd. No. 435 QianPu Road Chedun Town Songjiang District
201611 Shanghai P.R. China
Tel: +86 21 37746688 Fax: +86 21 37746600
E-Mail: info@keb.cn Internet: www.keb.cn

Republic of Korea | KEB America, Inc.
Room 1709, 415 Missy 2000 725 Su Seo Dong
Gangnam Gu 135- 757 Seoul Republic Korea
Tel: +82 2 6253 6771 Fax: +82 2 6253 6770
E-Mail: vb.korea@keb.de

Russian Federation | KEB RUS Ltd.
Lesnaya str, house 30 Dzerzhinsky MO
140091 Moscow region Russian Federation
Tel: +7 495 6320217 Fax: +7 495 6320217
E-Mail: info@keb.ru Internet: www.keb.ru

Spain | KEB America, Inc.
c / Mitjer, Nave 8 - Pol. Ind. LA MASIA
08798 Sant Cugat Sesgarrigues (Barcelona) Spain
Tel: +34 93 8970268 Fax: +34 93 8992035
E-Mail: vb.espana@keb.de

United Kingdom | KEB (UK) Ltd.
5 Morris Close Park Farm Industrial Estate
Wellingborough, Northants, NN8 6 XF United Kingdom
Tel: +44 1933 402220 Fax: +44 1933 400724
E-Mail: info@keb.co.uk Internet: www.keb.co.uk

United States | KEB America, Inc
5100 Valley Industrial Blvd. South
Shakopee, MN 55379 United States
Tel: +1 952 2241400 Fax: +1 952 2241499
E-Mail: info@kebamerica.com Internet: www.kebamerica.com



MORE KEB PARTNERS WORLDWIDE:

www.keb.de/company/representatives-agencies



Automation with Drive

www.kebamerica.com

KEB America, Inc. 5100 Valley Industrial Blvd S Shakopee, MN 55379 Tel. +1 952-224-1400 E-Mail: info@kebamerica.com